

Hand Actuated Lockables

User Manual



EN Instructions for fitting and use

Thank you for choosing

Hand Actuated Lockables from BraunAbility!

The following manual is an important part of the product, providing you with information on how to achieve maximum performance and safe operation. Keep the manual in a safe place so that you can refer to it when necessary.

If you have any questions about your equipment, please contact us.

Once again, thank you for placing your confidence in our products!



Safe vehicle adaptation solutions
*For your safety BraunAbility products are
designed and tested according to current
directives and standards.*

Safety information

- 4 Limitations of use

Fit and use

- 6 Fitting the Hand Actuated Lockable (HAL) to the seat leg
- 8 Adjusting HAL setting to the rail
- 10 Operating HAL

After care

- 12 Equipment storage and maintenance
- 12 Warranty

“Declaration of conformity” at the end of the manual.

Safety information

Limitation of use



This range of removable seat fixtures has been designed for use with a variety of seats where the intention is that they are easily moved within or removed from the vehicle.



If seatbelts are attached to the seat and the vehicle is to be sold within the EU, the vehicle builder will invariably require evidence that the assembly meets the appropriate Directives.



The removable seat fixture has been successfully tested and VCA witnessed to M1 loads applied to a single seat up to 30kg with three fixing bolts. If in doubt regarding a particular installation, refer to BraunAbility, the seat manufacturer or the vehicle builder.



*Removable seat fixtures should **ONLY** be fitted and used in the way described in this manual. If you have any queries on the installation or use of these products, please contact BraunAbility.*



BraunAbility warranty does not cover misuse of HAL integrated wheel. HAL wheel is designed to aid the movement and location of seats within the vehicle, using the product in situations other than this may give rise to the product not performing as required. BraunAbility reserves the right to assess any damage to the wheel.



Transport wheels are available for purchase, please contact our Sales Office for details. The transport wheels must be used with a 3 stud HAL version only.



When this Seat Fixture is used with a Phoenix Seating product additional parts may be required to ensure compliance with the Type Approved Installation. Parts and advice can be obtained from Phoenix Seating.

HAL2 - 2 Fixing Studs



HAL3 - 3 Fixing Studs



Fit and use

Fitting the Hand Actuated Lockable (HAL) to the seat leg

Note: Two removable seat fixtures are normally required for each seat. It is important that the seat legs are set to the identical rail width where the seat is to be fitted. Both HAL need to be aligned parallel to each other in the rail.

1. First, remove all M10 nyloc nuts and washers from sliding stud assemblies with a 17mm wrench (Fig. 1).
2. Ensure the seat is placed facing towards the front of the vehicle. Fit sliding studs through the seat leg bracket holes as shown above. Position both seat legs at approximately 5mm (1/4") from the front of the handle, ensuring alignment (Fig. 2).
3. Replace all washers and nuts and loosely fasten with a 17mm wrench (Fig. 3). Finally tighten the M10 nyloc nuts with a torque wrench to a recommended torque of : 35-40Nm (18-22lb.ft)

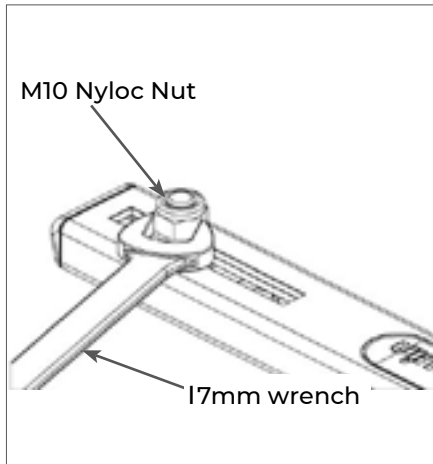

Figure 1

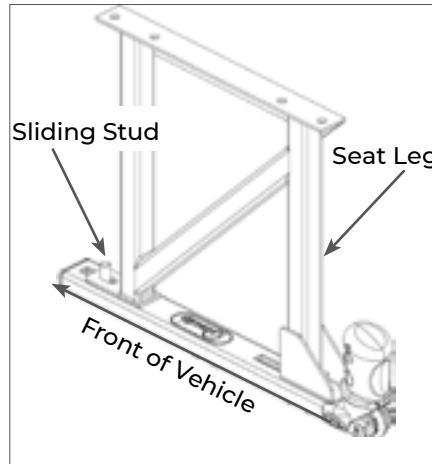

Figure 2

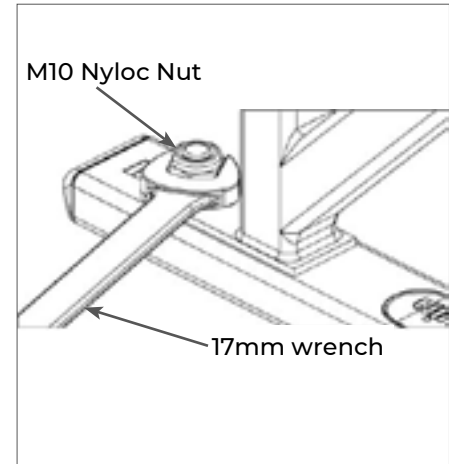

Figure 3



WARNING

In 3 stud version, the rear most fixing **MUST NOT** be used in isolation.
If it is intended that the seat should face the rear, please contact BraunAbility.

Fit and use

Adjusting HAL setting to the rail

HAL lockable comes with variable adjustable setting to accommodate different rail profiles and thicknesses. Each setting relates to a different thickness depth.

Setting 1: Thinner Rail Setting 2: Standard Rail Setting 3: Thicker Rail

1. Once HAL has been fitted to the seat leg, check that the lockables are on the right setting to fit the rail in your vehicle.
2. Place the seat in the rail with HAL unlocked (Fig. 4).
3. Try and lock the seat by pushing the handle forward to the locked position (Fig. 5):
 - A. The handle locks smoothly and the seat doesn't rattle; HAL is set correctly.
 - B. The handle is difficult to push forward; looking from the front, adjust HAL by inserting a 3mm allen key and rotating half turn clockwise . Once this is done try locking HAL again. (Repeat operation as necessary).
 - C. The handle locks too easily and rattles; looking from the front, adjust HAL by inserting a 3mm allen key and rotating half turn anti-clockwise. Once this is done try locking HAL again. (Repeat operation as necessary).

IMPORTANT: Tighten by hand only. Do not use tools of any kind.



Figure 4



Figure 5



Fit and use

Operating HAL

1. Before locating the seat into the rail, unlock HAL, by pressing the silver trigger (Fig 6) and then pull the handle fully back (Fig 7).
2. To locate the seat in the rail, align both HAL wheels into the rail, tilt the seat backwards slightly and wheel it along the rail to the right location. Once this is found, lower the seat into the rail gently push it forwards or backwards until it is located into the rail.
3. To lock the seat into the rail, push the handle forward to the upright position (Fig 8) until you hear it click.

Anti-tamper device

The anti-tamper device, which is supplied with HAL, is an optional accessory.

1. Should you choose to use this device during transportation, just clip it on to the silver trigger, making sure it is safely fitted (Fig 9).
2. To remove the device, simply push it sideways to release the silver trigger. Stow away securely.

Removing seat from rail

1. To release the seat from the rail, unlock HAL, by pushing handle forward while pressing the silver trigger (Fig 6), then pulling the handle fully back (Fig 7).
2. Tip the seat backwards and remove from the rail.



Figure 6



Figure 7



Figure 8

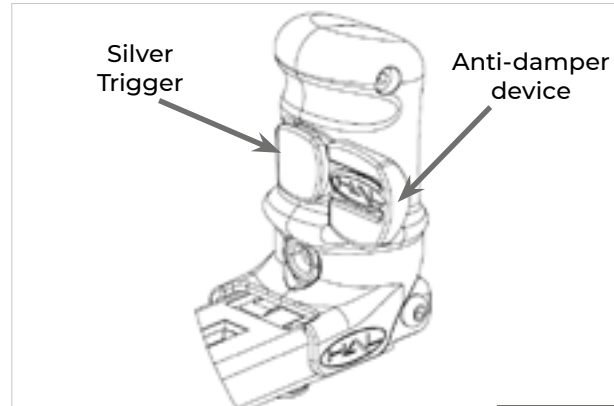

Figure 9

After care

Equipment storage and maintenance

Regularly inspect HAL for damage, wear or malfunction. If any problems are identified replace it immediately.

Warranty

BraunAbility products are extensively tested using BraunAbility anchorage systems, and our full warranty normally only applies to BraunAbility equipment when used with BraunAbility branded anchorages or as instructed.

BraunAbility have also participated in test programs with other manufacturers anchorage products and will support warranty on the BraunAbility products when used in conjunction with such jointly tested systems. For further details on specific applications please contact the Sales Office. In other situations, using BraunAbility products, for which BraunAbility has not participated in a joint test program, a limited BraunAbility warranty will apply.

Declaration of conformity

Manufacturer /

BraunAbility UK Ltd.
Unwin House
The Horseshoe Coat Road
Martock, Somerset, TA12 6EY
UK

Phone: +44 1935 827740
E-mail: sales.uk@braunability.eu
www.braunability.eu

Declares that the products /

HAL2, HAL3

Conforms to following directives standards and regulations /

2001/85/EC Annexe VII Paragraphs 3.8.2.8 & 3.8.2.9
76/115/EEC
R.14.07
R.107.06
BS EN 1789:2007+A2:2014

BraunAbility, Martock, 23rd April 2019

A handwritten signature in dark ink, appearing to read 'Rob Butcher', with a long horizontal line extending to the right.

Rob Butcher
Director of Engineering



Accredited by URS as testing laboratory in accordance with ISO/IEC 17025:2005
Quality system certified in accordance with ISO 9001:2008

Illustrations, descriptions and specifications in the user manual are based on current product information.
BraunAbility UK Ltd reserves the right to make alterations without previous notice.

© 2019 BraunAbility UK Ltd

BraunAbility UK Ltd

Unwin House
The Horseshoe, Coat Road
Martock, Somerset, TA12 6EY
UK

Phone: +44 1935 827 740
E-mail: info@braunability.eu
www.braunability.eu