

Solo Anchors



User Manual

EN Instructions for fitting and use

Thank you for choosing

Solo anchors from BraunAbility!

The following manual is an important part of the product, providing you with information on how to achieve maximum performance and safe operation. Keep the manual in a safe place so that you can refer to it when necessary.

If you have any questions about your equipment, please contact us.

Once again, thank you for placing your confidence in our products!



Safe vehicle adaptation solutions
*For your safety BraunAbility products are
designed and tested according to current
directives and standards.*

Safety information

- 4 Limitations of use
- 5 Before installing the Solo anchors

Fit and use

- 6 Fitting the floor anchorages
- 8 After fitting the floor anchorages

After care

- 9 Equipment storage and maintenance
- 9 Warranty

“Declaration of conformity” at the end of the manual.

Safety Information

General Guidance

- It is recommended that Solo floor anchors are installed only by an experienced technician/vehicle converter.
- Do not make any alterations to the Solo floor anchors.
- Do not install the floor anchors to unsound metal, wood, or plastic structures without additional and suitable reinforcement.
- These floor anchors meet the requirements of ISO 10542 & SAE J2249. Testing was conducted to the same configuration to that recommended by this guide, any deviation from the recommendation is the responsibility of the installer.
- The installer is responsible for ensuring that the fitting meets all applicable regulations. If in doubt about the method of installation or use please contact BraunAbility.



SA - Standard Floor Anchor



HVSAL - Long High Viz Floor anchor



SAS - Short Floor Anchor

Safety Information

Installation planning

- Position the wheelchair facing forward - centrally in the designated region of the vehicle.
- To minimise the potential for head injuries in an impact, allow a clear space of at least 400 mm behind and 650 mm, (FCZ, front clear zone), in front of the head of the wheelchair user, (Fig 1). The shoulder belt anchorage must be roof or side-wall anchored at a height level such that the belt webbing passes over the midpoint of the occupant shoulder and at a height that is at or just above the level of the occupants shoulders so as not to impose downward loads on the spine.
- A height provision (HHT) ranging from 1000mm to 1550mm should be made, depending on the size of the passenger. There should also be 200mm of clear space either side of the wheelchair centre line. If these clear space dimensions cannot be provided then any should be adequately padded and comply with impact performance requirements of ECE Regulation 21 'FMVSS 201'. All vehicle padding should comply with the flammability requirements of ECE Regulation 118 'FMVSS 302'. Guidance positions are shown in Fig. 2.
- Once happy with the planned wheelchair position, lay the floor anchors in their desired locations and check carefully immediately below the floor, that they and/or the hole cutter will not foul brake lines, fuel tanks, chassis members etc. If in doubt modify the wheelchair anchorage positions accordingly.
- **Note:** To successfully install the floor anchors, the floor thickness must not exceed 45mm.

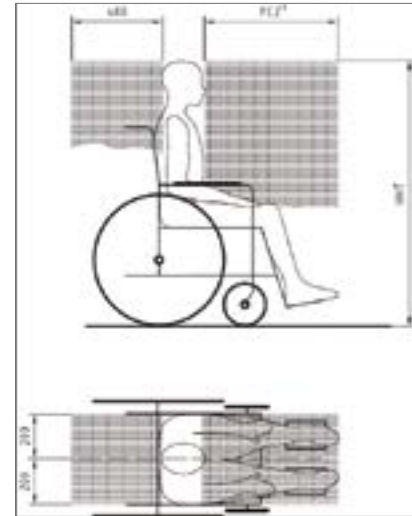

Figure 1

Note: seated head height (HHT) ranges from as low as 1000mm for a 6-year-old child to 1550mm for a tall adult.

Fit and use

Fitting the floor anchorages

1. Mark out the chosen floor anchor points, guidance positions are shown in Fig 2. Using a 25mm diameter hole saw and pilot drill arbour, or equivalent, cut through the finished floor, ply and steel flooring.
2. Counter bore the 25mm dia. hole to a diameter of 32mm and a depth of 8mm. This can be achieved by using a 'hole rework adaptor' and a 32mm dia. hole saw.
3. Clear debris and install the floor anchors, orientated as shown in Fig 2. Tighten to 30 Nm (Newton metres) from underneath using the nut, washer and under floor spreader plate (if applicable). **Note:** A special Solo wrench is available to hold the floor anchor whilst applying the locking torque. Please contact our Sales Office for details.
4. If you need to modify the spreader plate to clear an obstruction, always leave at least 15mm around the bolt hole. Any modification must be made such that the original load spreading properties are retained.
5. **Note:** It may be necessary to provide fillers between the vehicle floor convolutions to prevent these from being crushed when tightening up on the nuts.
6. It is recommended that some type of body sealant or foam fill is used between the under floor spreader plate and the vehicle under side to prevent ingress of water and subsequent saturation of the ply.



It is essential that the slot in each floor anchor is orientated as shown in Fig. 3

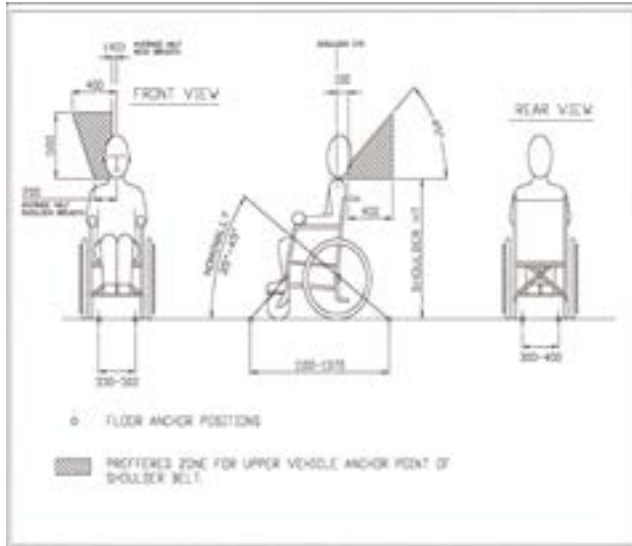

Figure 2

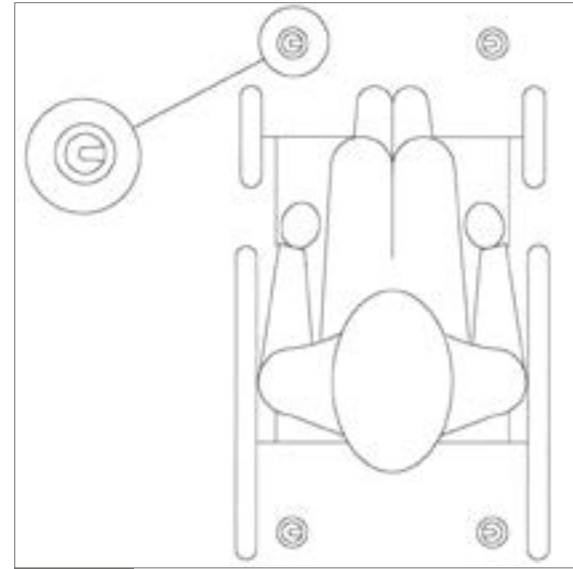

Figure 3

Fit and use

After fitting the floor anchorages

Check that each floor anchorage is operating correctly by attaching the tie-down straps to the floor anchors.

This is done by aligning the protrusion within each cleat to the slot on the floor anchors. Slide the cleat fully home, (this has the effect of raising the floor anchor from its housing) and rotate the assembly through 90° to lock.

To remove the cleat from the floor anchors, turn the cleat to align the raised protrusion on the cleat with the indent on the floor anchor and slide off.



After care

Equipment storage and maintenance

Solo floor anchors are made from stainless steel and therefore only require a periodic brush to remove debris from the slot and matting surfaces

Warranty

BraunAbility products are extensively tested using BraunAbility anchorage systems, and our full warranty normally only applies to BraunAbility equipment when used with BraunAbility branded anchorages or as instructed.

BraunAbility have also participated in test programs with other manufacturers anchorage products and will support warranty on the BraunAbility products when used in conjunction with such jointly tested systems. For further details on specific applications please contact the Sales Office. In other situations, using BraunAbility products, for which BraunAbility has not participated in a joint test program, a limited BraunAbility warranty will apply.

Declaration of conformity

Manufacturer /

BraunAbility UK Ltd.
Unwin House
The Horseshoe Coat Road
Martock, Somerset, TA12 6EY
UK

Phone: +44 1935 827740
E-mail: sales.uk@braunability.eu
www.braunability.eu

Declares that the products /

SA, SAS, SAL, HVSA, HVSAL, HVSAS

Conforms to following directives standards and regulations /

214/2014/EU Paragraphs 2.3.1 and 2.3.2.
R.14.07

BraunAbility, Martock, 16th April 2019

A handwritten signature in dark ink, appearing to read 'Rob Butcher', with a long horizontal line extending to the right.

Rob Butcher
Director of Engineering



Accredited by URS as testing laboratory in accordance with ISO/IEC 17025:2005
Quality system certified in accordance with ISO 9001:2008

Illustrations, descriptions and specifications in the user manual are based on current product information.
BraunAbility UK Ltd reserves the right to make alterations without previous notice.
© 2019 BraunAbility UK Ltd

BraunAbility UK Ltd
Unwin House
The Horseshoe, Coat Road
Martock, Somerset, TA12 6EY
UK

Phone: +44 1935 827 740
E-mail: info@braunability.eu
www.braunability.eu