

Owner Manual

International

# Vista 2

# 63" Split Platform

Public Use  
Wheelchair Lifts



[www.braunability.com/international](http://www.braunability.com/international) ISO 9001:2008

631 West 11th Street, Winamac, IN 46996, USA

Phone: +1 574 946 6153

Fax: +1 574 946 4670

38250 Rev. B

April

2014



Original Instructions



## Congratulations

The BraunAbility employee family thanks you for purchasing your new wheelchair lift. We design and build each BraunAbility product for reliability, quality and safety. Our founder, Ralph Braun, instilled that ethic from day one and we live by that commitment today.

This manual includes operating instructions, safety precautions and maintenance procedures for your new wheelchair lift. As long as it's properly maintained and operated, your BraunAbility lift will provide mobility freedom for years.

Thank you again for your business, and enjoy your independence!

Sincerely,

The BraunAbility Employee Family

---

## Warranty

Consult your local BraunAbility dealer regarding warranty policy.

[www.braunability.com/international](http://www.braunability.com/international)

<b>The Braun Corporation®</b> INDIANA, USA	
MODEL NUMBER XXXXXXXXXX	→ Model No. _____
SERIAL NUMBER XX-XXXXX	→ Serial No. _____
MFG DATE XX/XX/XXXX	→ Date of Manufacture _____
CE	

Sample Serial No./Series No. Identification Tag

Model No.      Serial No.

<b>OWNER'S WARRANTY REGISTRATION</b>	
XXXXXXXXXX	XX-XXXXX
PURCHASED FROM _____	
OWNER _____	
NAME _____	DATE INSTALLED _____
ADDRESS _____	
CITY _____	
TELEPHONE _____	STATE _____ ZIP _____
TO VALIDATE WARRANTY REGISTRATION CARDS MUST BE RETURNED TO THE BRAUN CORPORATION.	

Sample Warranty/Registration Card

## Contents

Installation and Service Safety Precautions .....	2 - 3
Lift Operation Safety .....	4 - 6
Specifications .....	7
Lift Terminology .....	8
Center of Gravity .....	9
Lift Installation	
Position Lift .....	10 - 11
Secure Lift .....	12
Attach Power and Ground Cables .....	13 - 14
Connect Interlock .....	15
Lift Operating Instruction Decal .....	15
Platform Angle Adjustment .....	16
Turnbuckle Adjustment .....	17 - 18
Platform Half Stabilizer Roller Installation and Adjustment ....	19
Roll Stop Anti-Rattle Installation and Adjustment .....	20
Tower Microswitch Adjustment .....	21 - 22
Installer Verification .....	23 - 24
Lift Operation Safety .....	25 - 27
Lift Operating Instructions .....	28 - 30
Manual Operating Instructions .....	31 - 32
Emergency Stop (E-Stop) Operating Instruction .....	33
Maintenance and Lubrication Schedule .....	34 - 40
Declarations	
Declaration of Conformity - Machinery .....	41
Declaration of Noise Emission .....	42
Declaration of Conformity - EMC .....	43

---

## Document Cross Reference

Service Manuals 38251

## Installation and Service Safety Precautions

### Safety Symbols

**SAFETY FIRST!** Know That....

**A** The information contained in this manual and supplements (if included), is provided for your use and safety. Familiarity with proper installation, operation, maintenance and service procedures is necessary to ensure safe, trouble free lift operation. Safety precautions are provided to identify potentially hazardous situations and provide instruction on how to avoid them.

**B**

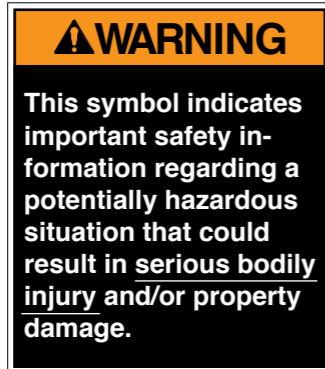

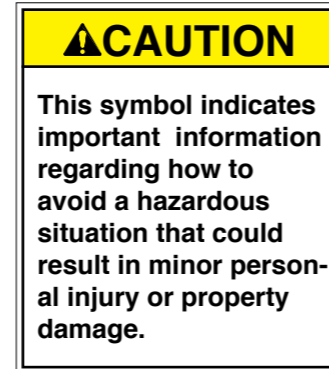

**C**





**D** **NOTICE** Additional information provided to help clarify or detail a specific subject.

**E**  This symbol indicates that there are dangerous energy levels present inside the enclosure of this product. To reduce the risk of fire or electric shock, do not attempt to open the enclosure or gain access to areas where you are not instructed to do so. Refer servicing to qualified service personnel only.

**F**  This symbol indicates that a condition where damage to the equipment resulting in injury to the operator could occur if operational procedures are not followed. To reduce the risk of damage or injury, refer to accompanying documents, follow all steps or procedures as instructed.

**G**  This symbol indicates that a condition where injury or damage could occur if contact is made with the hot surface.

**H**  This symbol indicates an area to avoid bodily contact to prevent injury.

**I**  This symbol indicates the presence of high pressure hydraulic hoses. Use appropriate personal protective equipment when working on hydraulic system.

**J**  This symbol indicates the presence of a fire hazard. Avoid open flames or sparks when working with flammable materials to prevent injury or damage.

**K**  This symbol indicates a device weighs in excess of 139kg (306 lbs). Use of a fork lift or hoist is required.

These symbols will appear throughout this manual as well as on the labels posted on your lift. **Recognize the seriousness of this information.**

## Installation and Service Safety Precautions

### Service Safety Precautions

**⚠ WARNING**  
If installation, maintenance or repair procedures cannot be completed exactly as provided in this manual or if the instructions are not fully understood, contact BraunAbility immediately. Failure to do so may result in serious bodily injury and/or property damage.

**⚠ WARNING** Read this manual, supplement(s) and lift-posted operating instructions decals before performing installation, operation, or service procedures.

**⚠ WARNING** Use appropriate personal protective equipment when installing and servicing lift.

**⚠ WARNING** Remove any obstructions within the lift mounting/operating area prior to beginning installation procedures.

**⚠ WARNING** Install lift and power platform to fully folded position before removing shipping straps.

**⚠ WARNING** Do not fold or unfold the platform prior to positive securement of base plate mounting hardware.

**⚠ WARNING** Check for obstructions such as gas lines, wires, exhaust, etc. before drilling or cutting during installation procedures.

**⚠ WARNING** Route all cables clear of exhaust system, other hot areas, moving parts, wet areas, etc.

**⚠ WARNING** Risk of electrical shock or fire! Use extra care when making electrical connections. Connect and secure as outlined in Installation Instructions and Wiring Diagrams.

**⚠ WARNING** Adjust platform angle and floor level positioning of bridge plate before operating lift with passenger.

**⚠ WARNING** Maintenance and repairs must be performed only by authorized service personnel.

**⚠ WARNING** Perform maintenance and lubrication procedures exactly as outlined in the Maintenance and Lubrication Schedule contained in this manual.

**⚠ WARNING** Disconnect the power cable at the battery prior to servicing.

**⚠ WARNING** Never modify (alter) a BraunAbility lift.

**⚠ WARNING** Replacement parts must be BraunAbility authorized replacements.

**⚠ WARNING** Never install screws or fasteners (other than factory equipped).

**⚠ WARNING** Whenever replacing a hydraulic cylinder or seals, lower platform fully.

**⚠ WARNING** Failure to follow these safety precautions may result in serious bodily injury and/or property damage.

## Lift Operation Safety

### Safety Symbols

**SAFETY FIRST!** Know That....

**A** The information contained in this manual and supplements (if included), is provided for your use and safety. Familiarity with proper installation, operation, maintenance and service procedures is necessary to ensure safe, trouble free lift operation. Safety precautions are provided to identify potentially hazardous situations and provide instruction on how to avoid them.

**B**

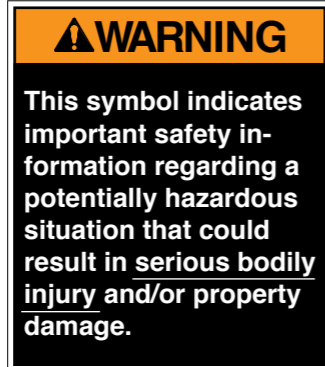

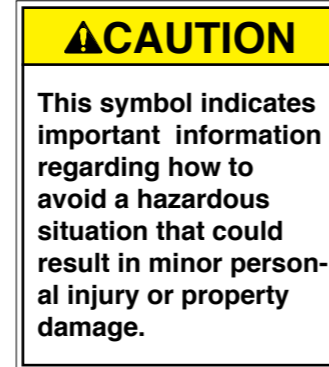

**C**





**D** **NOTICE** Additional information provided to help clarify or detail a specific subject.

**E**  This symbol indicates that there are dangerous energy levels present inside the enclosure of this product. To reduce the risk of fire or electric shock, do not attempt to open the enclosure or gain access to areas where you are not instructed to do so. Refer servicing to qualified service personnel only.

**F**  This symbol indicates that a condition where damage to the equipment resulting in injury to the operator could occur if operational procedures are not followed. To reduce the risk of damage or injury, refer to accompanying documents, follow all steps or procedures as instructed.

**G**  This symbol indicates that a condition where injury or damage could occur if contact is made with the hot surface.

**H**  This symbol indicates an area to avoid bodily contact to prevent injury.

**I**  This symbol indicates the presence of high pressure hydraulic hoses. Use appropriate personal protective equipment when working on hydraulic system.

**J**  This symbol indicates the presence of a fire hazard. Avoid open flames or sparks when working with flammable materials to prevent injury or damage.

**K**  This symbol indicates a device weighs in excess of 139kg (306 lbs). Use of a fork lift or hoist is required.

These symbols will appear throughout this manual as well as on the labels posted on your lift. **Recognize the seriousness of this information.**

## Lift Operation Safety

### Lift Operation Safety Precautions

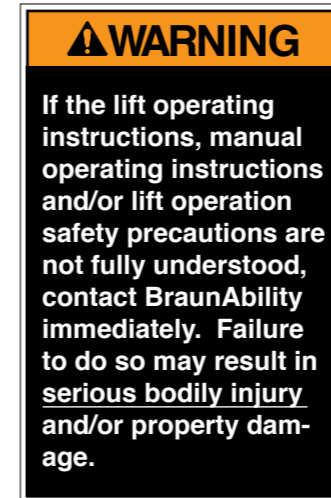

- ▲WARNING** Read manual and supplement(s) before operating lift. Read and become familiar with all safety precautions, operation notes and details, operating instructions and manual operating instructions before operating the lift.
- ▲WARNING** Load and unload on level surface only.
- ▲WARNING** Engage vehicle parking brake before operating lift.
- ▲WARNING** Provide adequate clearance outside the vehicle to accommodate the lift before opening lift door(s) or operating lift.
- ▲WARNING** Inspect lift before operation. Do not operate lift if you suspect lift damage, wear or any abnormal condition.
- ▲WARNING** Do not use as a link bridge.

**▲WARNING** Keep operator and bystanders clear of area in which the lift operates.

**▲WARNING** Lift attendant must observe passenger at all times during lift operation.

**▲WARNING** Ensure adequate lighting exists in the lift operating area.

**▲WARNING** Whenever a wheelchair passenger (or standee) is on the platform, the:

- Passenger must be positioned fully inside yellow boundaries facing outward.
- Wheelchair brakes must be locked
- Bridge plate and roll stop must be up (vertical)
- Roll Stop latch must be fully engaged
- Passenger should grip both handrails (if able).

**▲WARNING** Wheelchair lift attendants should be instructed on any special needs and/or procedures required for safe transport of wheelchair passengers.

**▲WARNING** Load and unload clear of vehicular traffic.

**▲WARNING** Do not attempt to load or unload a passenger in a wheelchair or other apparatus that does not fit on the platform area.

**▲WARNING** The lift attendant shall not ride on the platform with the passenger. The lift is intended for use by a single passenger.

**▲WARNING** Do not overload or abuse. The load rating applies to both the raising and lowering functions.

**▲WARNING** Use caution when operating this equipment out of doors during electrical storms or similar electrical phenomena.

**▲WARNING** Use caution when operating this equipment in severe weather or environmental conditions (fog, rain, snow, ice, dust, etc.)

**▲WARNING** Discontinue lift use immediately if any lift or vehicle interlock does not operate properly.

**▲WARNING** Do not operate or board the lift if you or your lift operator are intoxicated.

## Lift Operation Safety

- ⚠WARNING** Do not raise front wheelchair wheels (pull wheelie) when loading, boarding, or riding on the platform.
- ⚠WARNING** Open lift door(s) fully and secure before operating lift.
- ⚠WARNING** Position and secure (buckle, engage, fasten, etc.) the wheelchair-equipped occupant seat belt (torso restraint) before loading onto the wheelchair lift platform.
- ⚠WARNING** Lift attendants must ensure that lift occupants keep hands, arms and all other body parts within the lift occupant area and clear of moving parts.
- ⚠WARNING** Platform must be positioned at floor level (bridging position) when loading or unloading in and out of vehicle.
- ⚠WARNING** Do not use platform bridge plate or roll stop as a brake. Stop and brake wheelchair when loading onto the platform (manually stop and brake manual wheelchairs — stop powered wheelchairs with the wheelchair controls).
- ⚠WARNING** Turn powered (electric) wheelchairs off when on lift platform.
- ⚠WARNING** Press the DOWN switch until the entire platform rests on ground level (lowered fully) and the roll stop is fully unfolded (ramp position) before loading or unloading a passenger at ground level.
- ⚠WARNING** Roll stop must be fully unfolded (ramp position) until front and rear wheelchair wheels cross the barrier when loading or unloading at ground level.
- ⚠WARNING** Accidental activation of control switch(es) may cause unintended operation(s).
- ⚠WARNING** Maintenance and lubrication procedures must be performed as specified in this manual by authorized (certified) service personnel.
- ⚠WARNING** Replace missing, worn or illegible decals.
- ⚠WARNING** Never modify (alter) a BraunAbility lift.
- ⚠WARNING** Do not use accessory devices not authorized by BraunAbility.
- ⚠WARNING** Do not remove any guards or covers.
- ⚠WARNING** Keep clear of any hydraulic leak.
- ⚠WARNING** Failure to follow these safety precautions may result in serious bodily injury and/or property damage.

## Specifications



The lift must be installed, operated, and maintained as detailed in applicable manuals. Any use of equipment other than instructed in this manual is prohibited.

The 363kg (800 lb.) lift capacity Vista-2 series lifts have completed 15,600 cycles with a 363kg load and a static load test with a 1090kg (2400 lb.) load.

The specifications below reflect CE standards. Lifts meet or exceed these requirements.

### Operating Temperature

This equipment will operate in its intended ambient at a minimum between -30°C and 65°C.

### Relative Humidity

This equipment will operate correctly within an environment at 50% RH, at 40°C.

### Altitude

This equipment will operate correctly up to 1000m above mean sea level.

### Sound Pressure Level

The emission sound pressure level at the operator's position is expected not to exceed 70 db(A).

### Transportation and Storage

This equipment will withstand, or has been protected against, transportation and storage temperatures of -25°C to +55°C, and for short periods of up to +70°C.

The lift has been packaged to prevent damage from the effects of normal humidity, vibration, and shock.

Lift Model	Maximum Load Capacity	Power Requirement	Lift Weight
VL998IB3463RP-2	363kg (800lbs)	12 VDC	181kg (398lbs)

## Lift Terminology

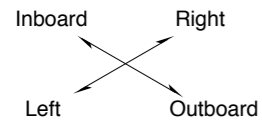
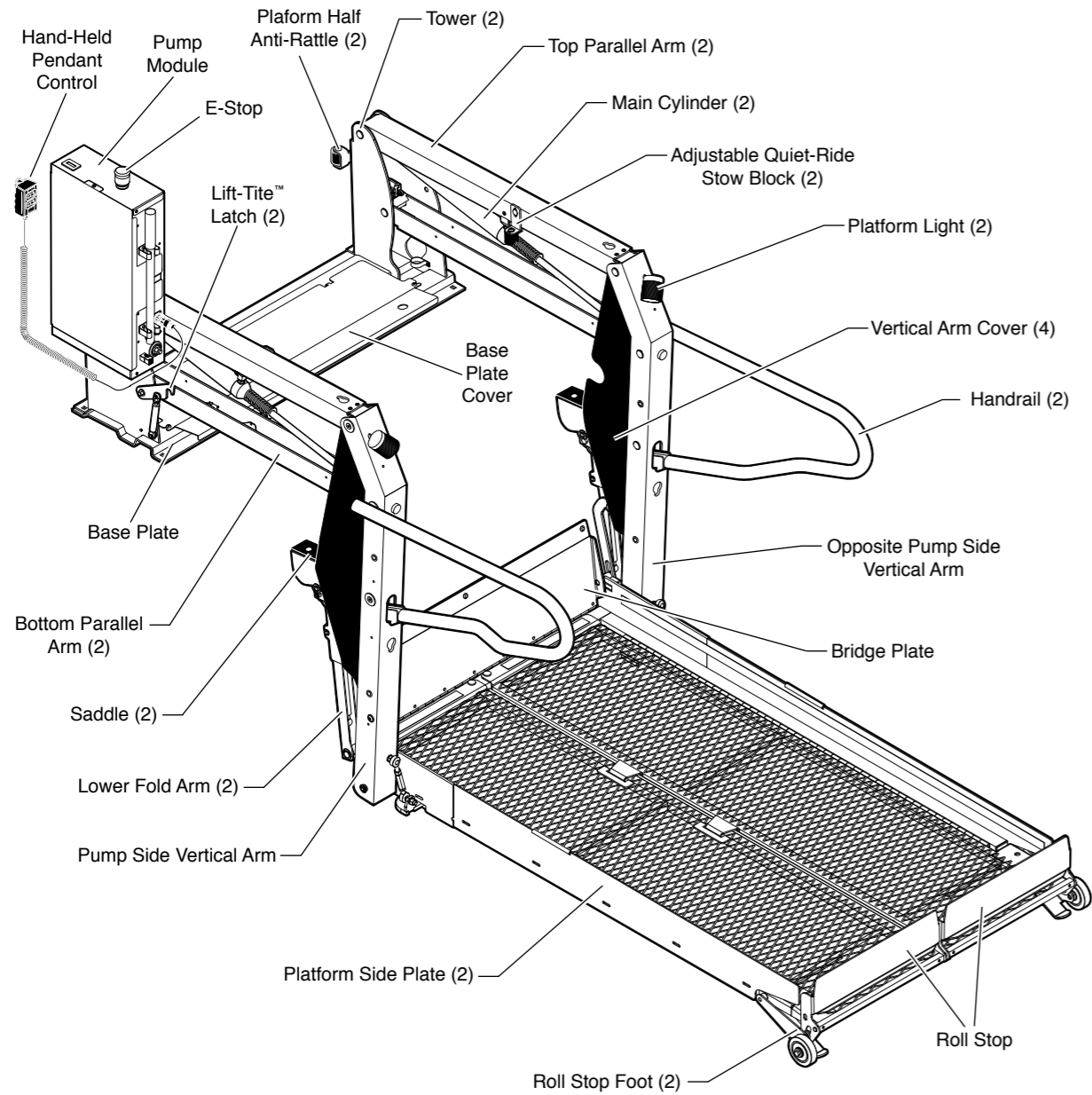

## Center of Gravity

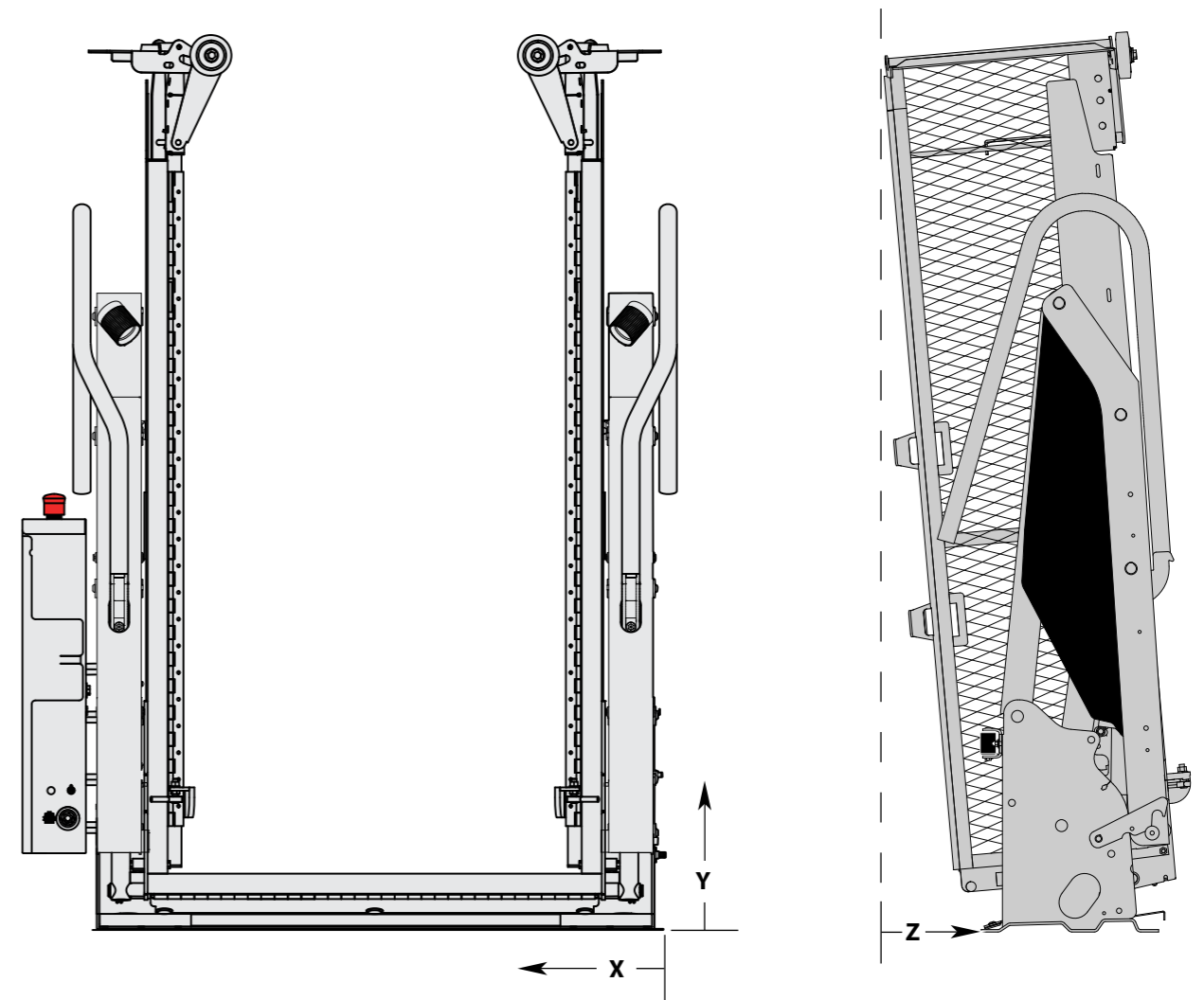

Center of Gravity is the intersection of X, Y, and Z.  
 Notice: X must be measured from opposite pump side as shown.

Lift Model	X (cm)	Y (cm)	Z (cm)
VL998IB3463RP-2	63.15	70.75	22.07

BraunAbility wheelchair lifts provide a method of boarding and exiting applicable motor vehicles. BraunAbility wheelchair lifts accommodate wheelchair passengers, standees, and other mobility aid users.



The lift must be installed, operated, and maintained as detailed in this manual. Any use of equipment other than instructed in this manual is prohibited.

## Lift Installation

### Position Lift

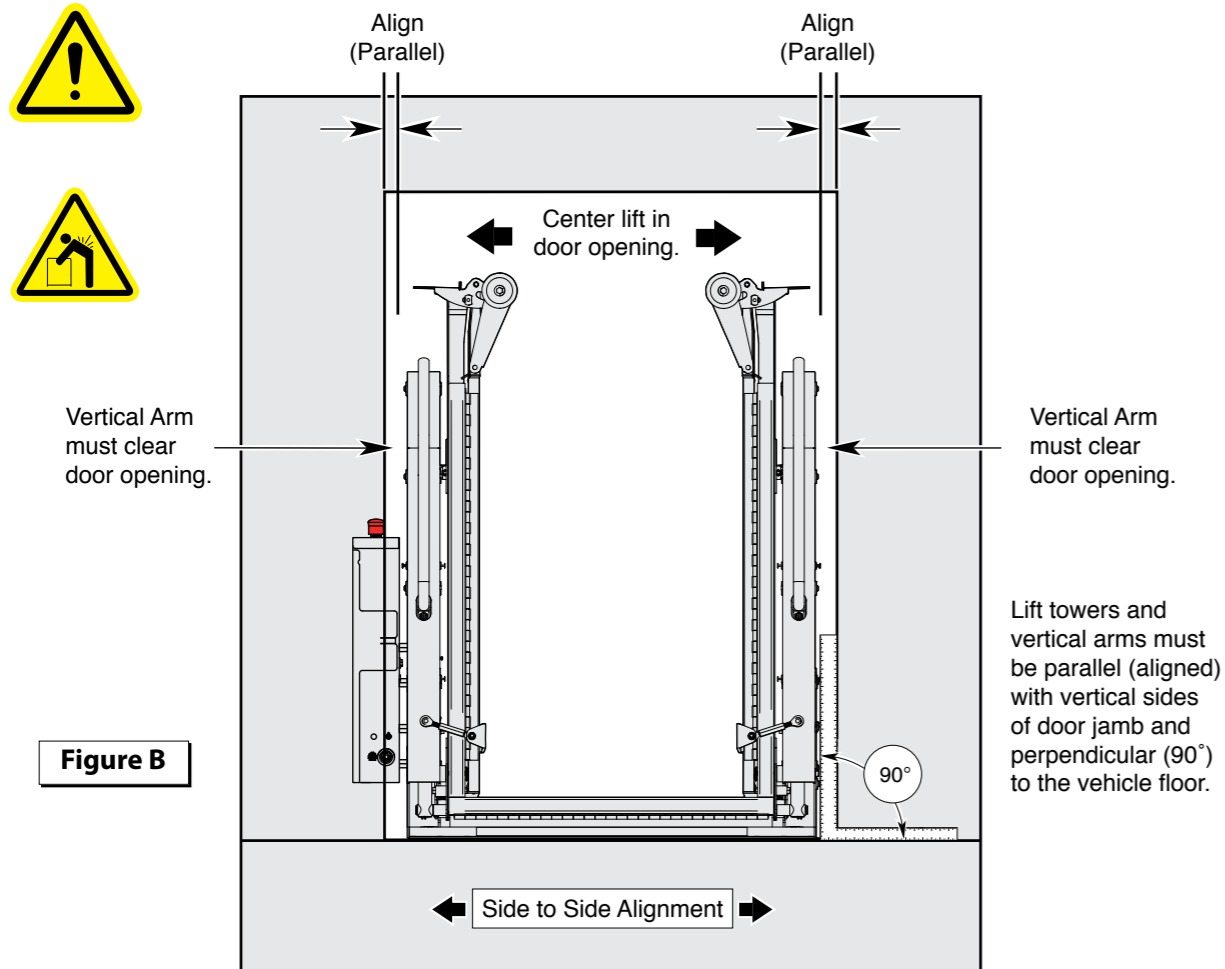

### Clearance:

Center the lift in the opening. See Figure B. Position the base plate parallel to (aligned with) the door opening as shown in Figure C. Close the vehicle door(s).

Position lift as close to the door opening as possible while maintaining a minimum clearance of 12 mm between the lift and the door or wall. See Figure D.

**Lift-Tite® Latches:** When checking vehicle wall clearance - allow the lift to drift fully into the Lift-Tite® latches to ensure clearance (should drift occur). See Figure F. Using the hand pump handle, stroke the hand pump to stow the lift fully. Then open the valve slightly (1/2 turn only), and allow the Lift-Tite® latches to engage the vertical arm pins fully. Close pump valve.

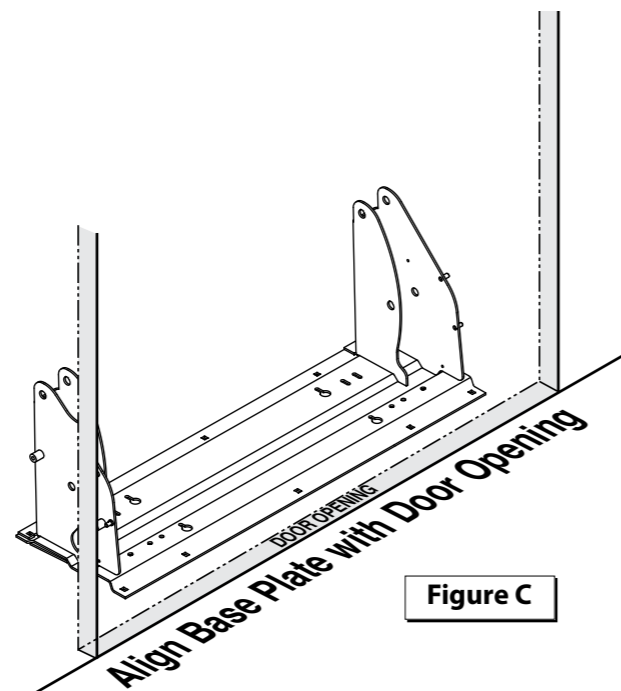

Figure C

## Lift Installation

### Position Lift

### Alignment:

**Side-to-Side Alignment:** See Figure B on previous page. The lift vertical arms and platform should be perpendicular (90°) to the vehicle floor and parallel (aligned) with the vertical sides of door jamb. The vertical arms and the parallel arms must clear the door opening when the lift folds and unfolds.

**Inboard-to-Outboard Alignment:** See Figure D. The vertical arms and parallel arms must be aligned and parallel to each other. See Figure D. The lift towers should be perpendicular (90°) to the vehicle floor (except when base plate wedges are used).

**Step well Installations:** It is not permissible for the base plate to overhang the step well. Base plate support must be constructed in the step well for lift support. The structure must be level with the existing floor and of equivalent construction (structural strength).

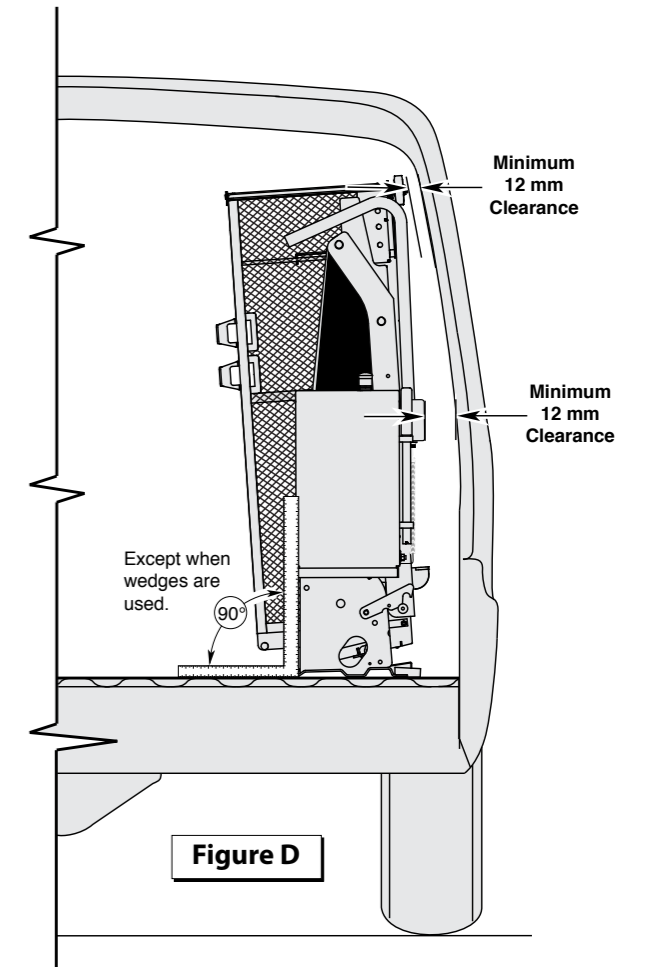
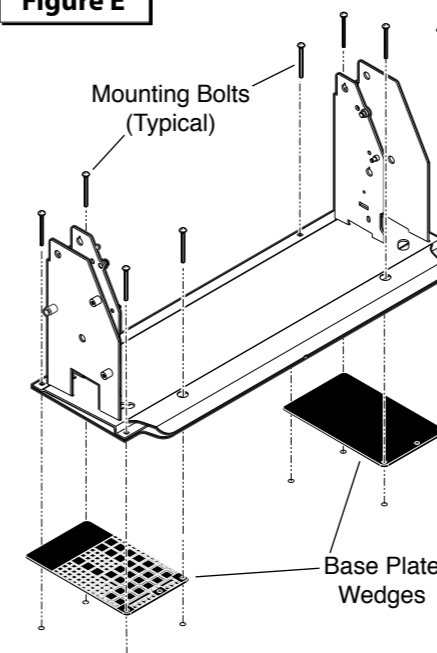

Figure E



**Base Plate Wedges:** The top of the lift may need to be tilted inboard slightly to provide the minimum 12mm clearance. Position wedges as shown in Figure E.

Install wedges to increase platform and vertical arm clearance between lift and vehicle.

Figure F

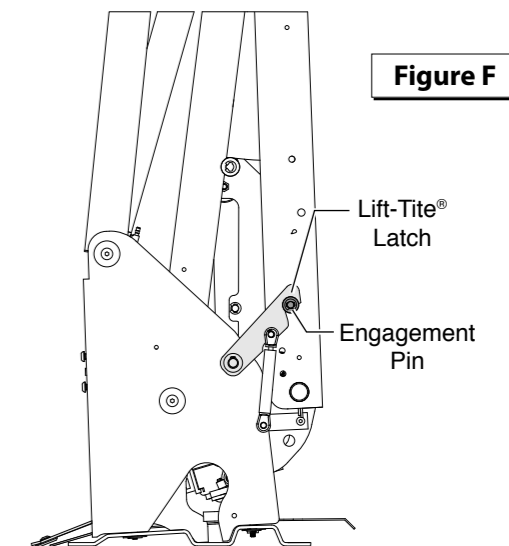

**Lift-Tite® Latches:** When checking vehicle wall clearance - allow the lift to drift fully into the Lift-Tite® latches to ensure proper clearances.



## Lift Installation

### Secure lift

Figure G



**WARNING**  
Check for obstructions such as gas lines, wires, exhaust, etc. before drilling or cutting. Failure to do so may result in serious bodily injury and/or property damage.

1. Drill two mounting holes (holes 6 and 7).
  2. Temporarily secure lift using two mounting bolts (holes 6 and 7).
  3. Manually deploy lift and check lift clearance. Drill remaining mounting holes.
  4. Install below floor mounting hardware per instructions supplied in kit.
  5. Tighten mounting bolts 1 through 8 per sequence detailed above. Note deflection detail below.
- Mounting Bolt Torque Target: 40 Nm.**

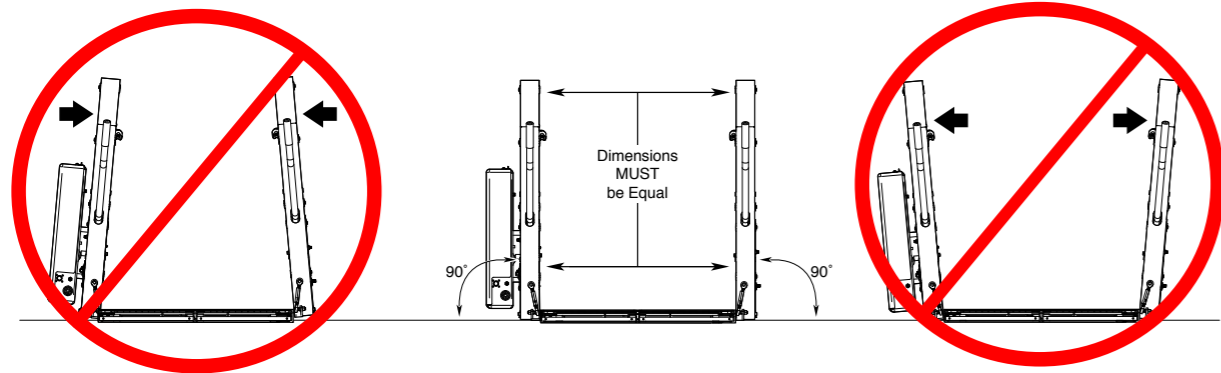

To Correct:

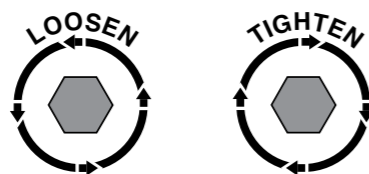
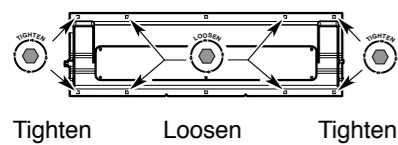

To Correct:

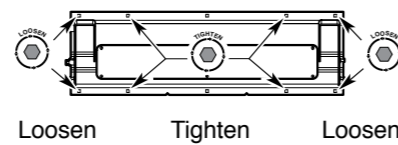

Figure H

## Lift Installation

### Attach Power and Ground Cables

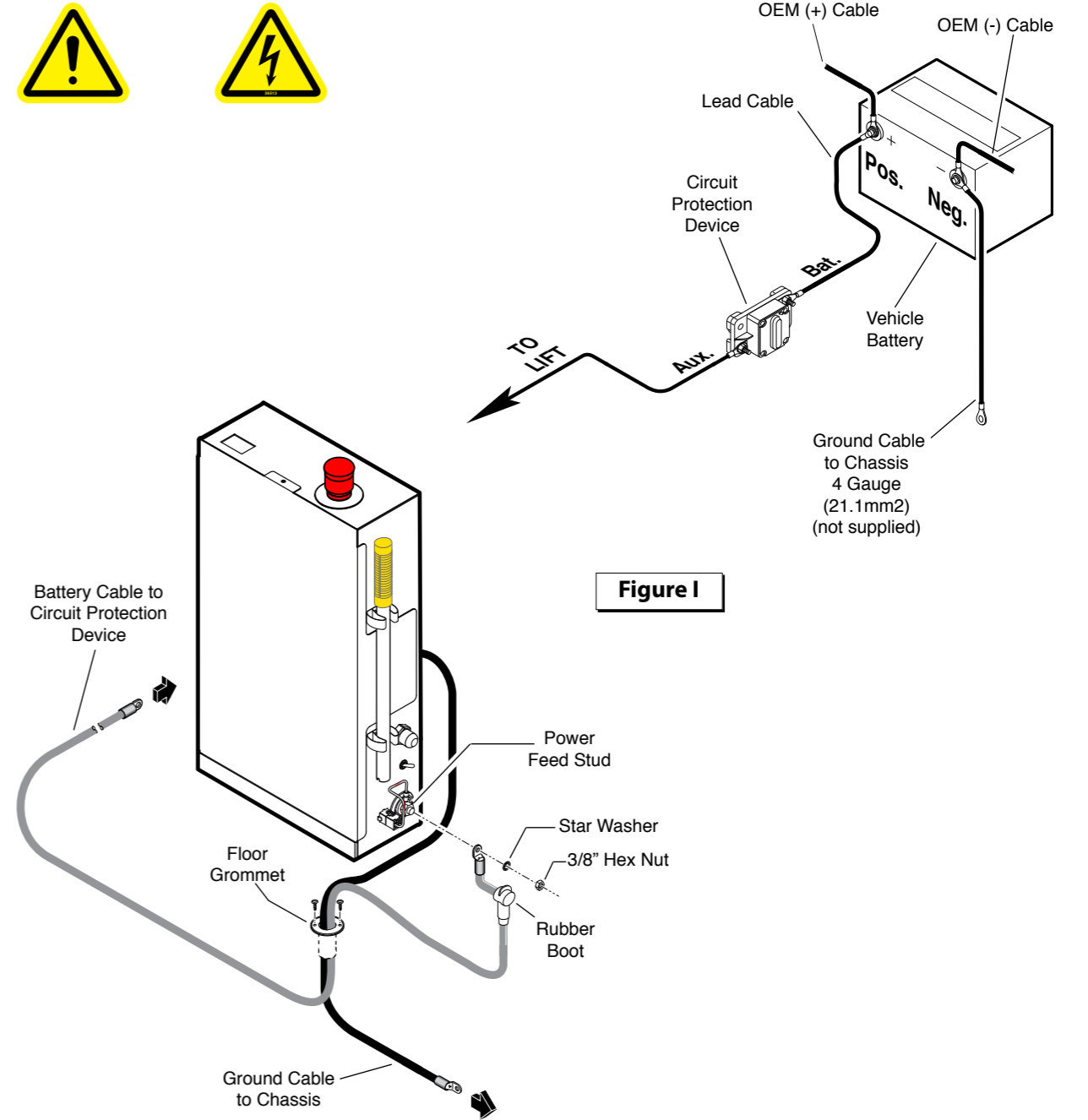

Figure I

1. Drill 28.5mm diameter grommet access hole. Check under the vehicle for obstructions.
2. Insert grommet. Secure grommet with two self-tap screws.
3. Route ground and power cables through grommet. Route cables clear of exhaust, other hot areas and moving parts.
4. Connect ground and power cables.

#### Vehicle Battery Positive Cable:

Install in-line circuit protection device as shown in Figure I. Attach power cable and lead cable as shown.

## Lift Installation

### Attach Power and Ground Cables

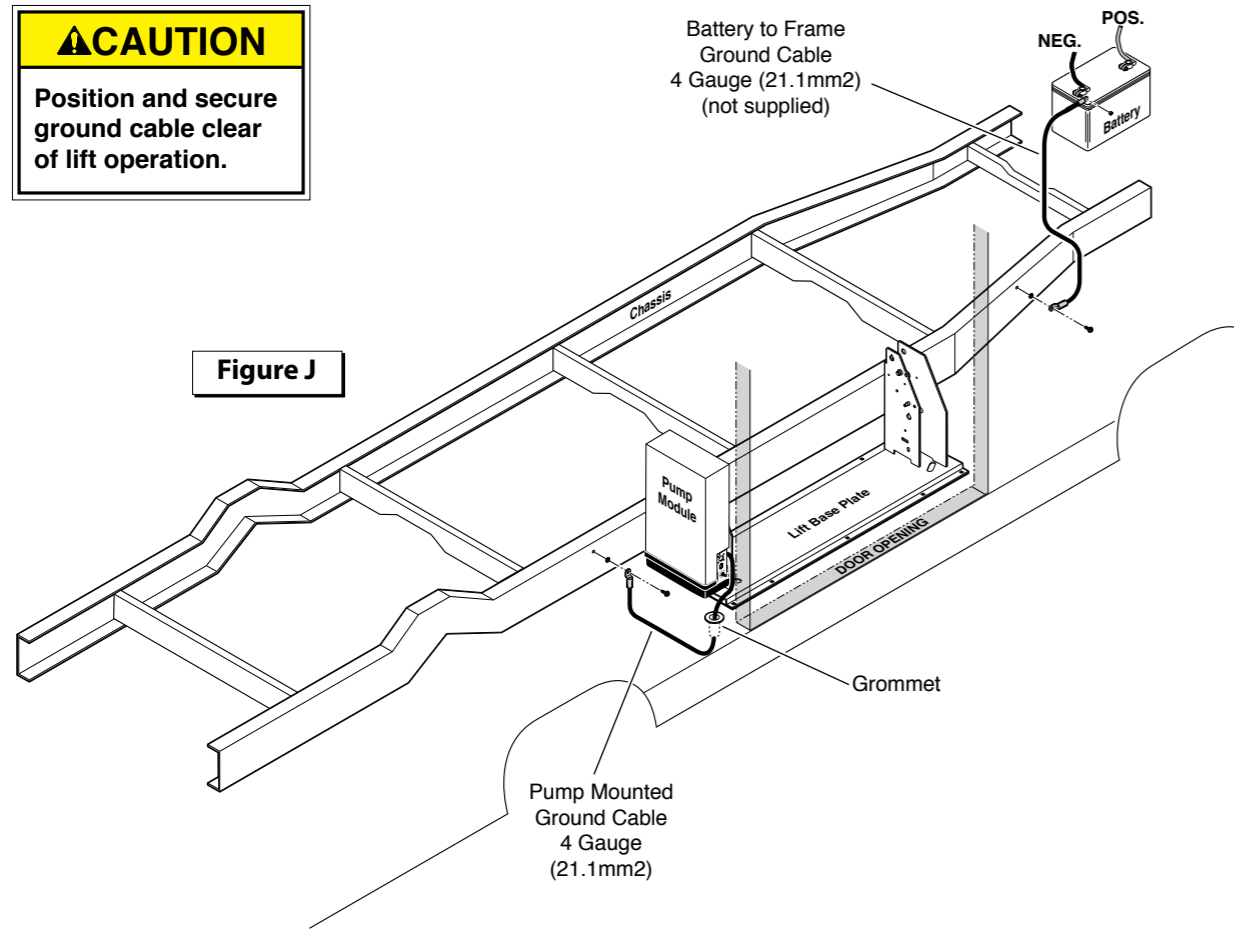

Figure J

#### Pump Ground Cable:

Route the pump mounted cable through the floor grommet and connect to a vehicle framing member as shown. See Figure J.

#### Vehicle Battery Ground Cable:

A 4 gauge (21.1mm<sup>2</sup>) ground cable must be connected from vehicle battery negative post to the same vehicle framing member the pump ground cable is attached to. See Figure J.

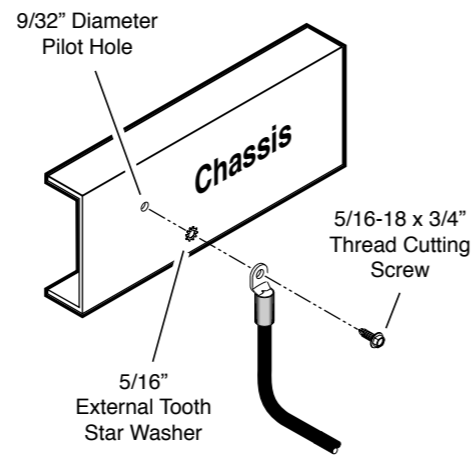

Mounting Hardware Detail

**Ground Cable Corrosion:** When mounting ground cables, remove undercoating, dirt, rust, etc. from framing member around mounting holes (minimum 16mm diameter area). Apply protective coating to mounting holes to prevent corrosion. Failure to do so will void warranty of certain electrical components.

## Lift Installation

### Connect Interlocks



#### Vehicle and Lift Interlocks

The pump module is equipped with a lift interface 9-circuit connector (female socket). A mating 9-circuit connector (male plug) is supplied.

To meet minimum CE requirements, connect to vehicle interlock harness as outlined below (Steps 1-5).

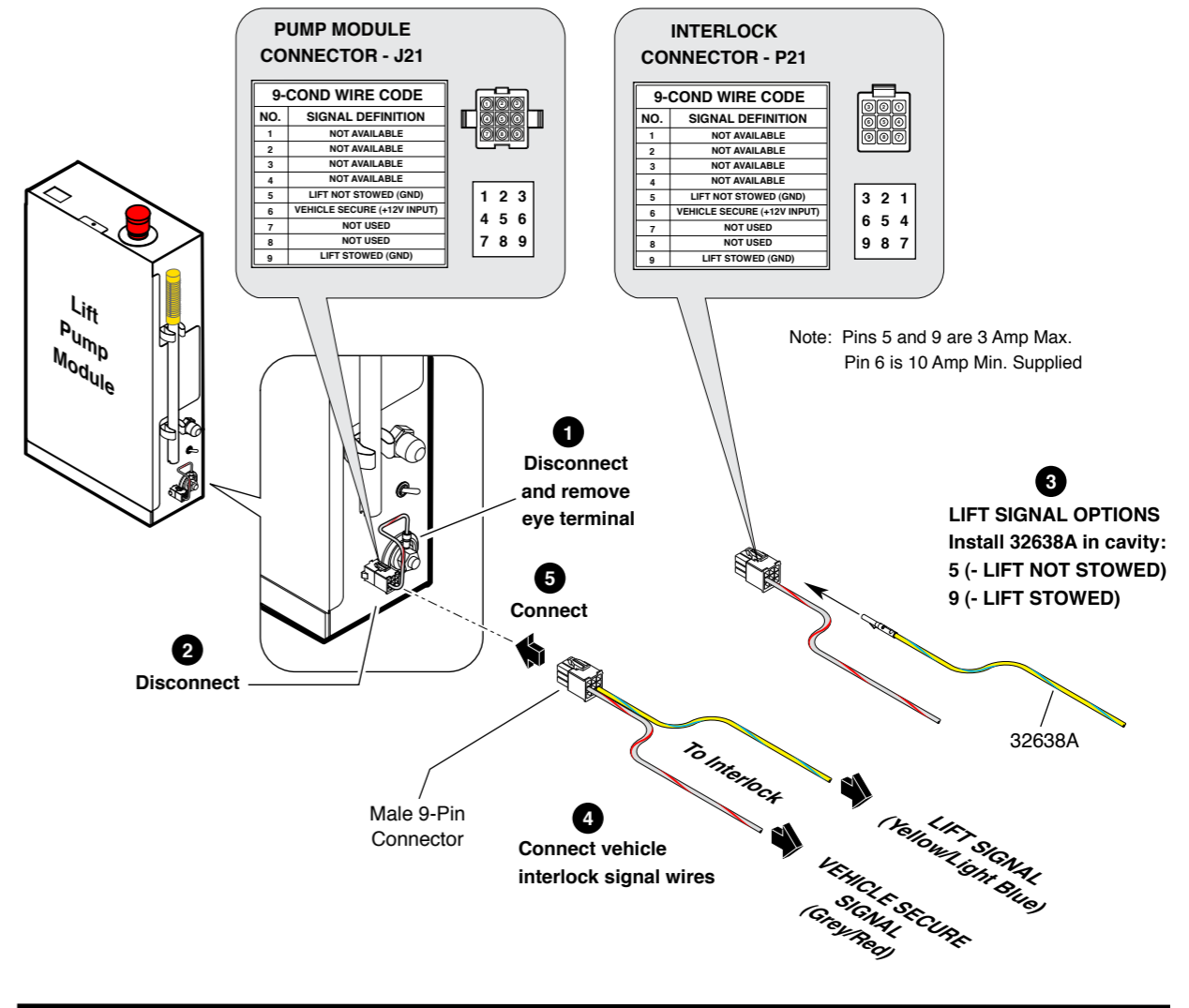

Note: Pins 5 and 9 are 3 Amp Max. Pin 6 is 10 Amp Min. Supplied

### Lift Operating Instructions Decal

Affix Lift Operating Instructions decal to vehicle door in a highly visible location near the hand-held pendant control (lift operator position).

Replace any missing, worn, or illegible decals.

Notice: Clean surfaces with isopropyl alcohol before decal application. Use a clean cloth or paper towel. Do not use oily shop rags. Wipe surface free of residue with dry portion of cleaning cloth.

## Lift Installation

### Platform Angle Adjustment



#### Lowering Sequence Requirements

1. The outboard end (toe) of the platform must contact the ground first to ensure the spring-loaded outer barrier unfolds fully. See Figure B.
2. The inboard end (heel) of the platform must lower fully (turnbuckle brackets must contact ground when fully lowered). See Figure B.

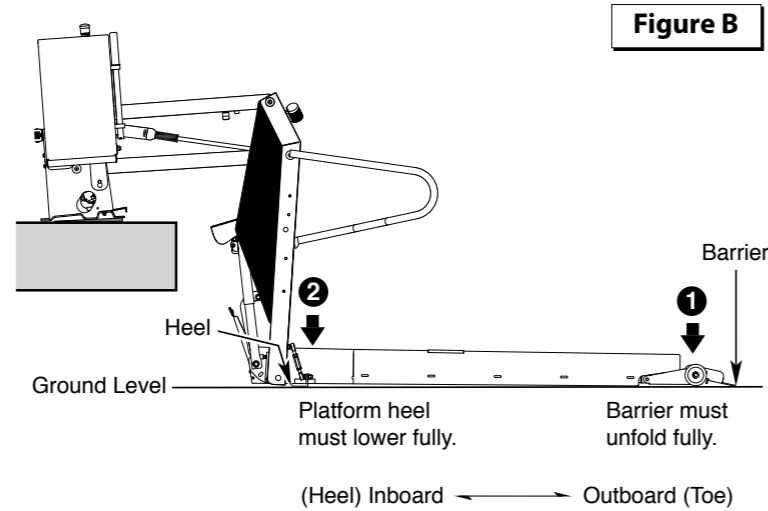

Figure B

The angle of the platform at ground level directly affects the angle of the platform when positioned at floor level.

Raise the platform to floor level. Note the angle of the platform.

The platform at floor level should have a slight upward angle as shown in Figure C.

Adjust platform angle as detailed below.

#### Adjustment Procedure:

Platform angle adjustment Allen screws are provided on each side of the platform (see photo at right).

Turn adjustment screws clockwise to raise the outboard end of the platform. Turn adjustment screws counterclockwise to lower the outboard end of the platform.

Both adjustment screws must be adjusted equally.

**Platform Stop Blocks:** When adjusting platform angle, ensure both stop blocks are making full contact with the vertical arms (see photo at right).

#### Floor Level Adjustment:

Following platform angle adjustment, set platform floor level positioning as detailed in Tower Microswitch Adjustment. Check platform angle again after performing Tower Microswitch Adjustment procedures.

**Turnbuckles:** Platform turnbuckles will be affected if platform angle is adjusted. Adjust turnbuckles as detailed in Turnbuckle Adjustment section if needed.

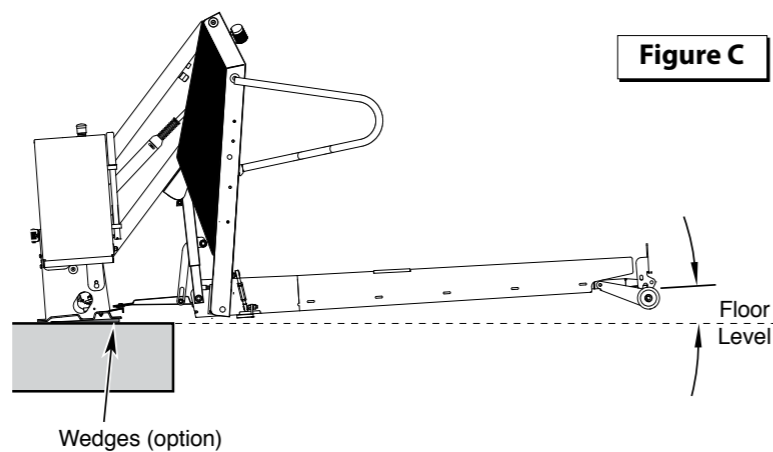
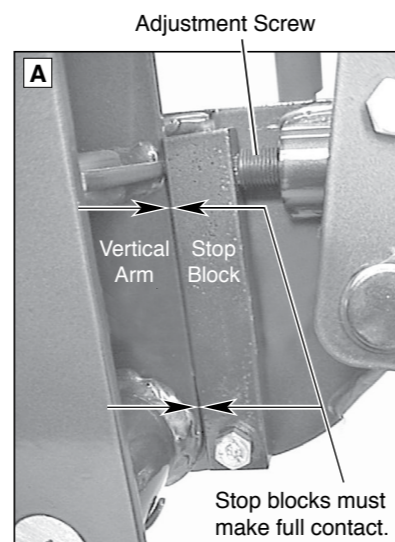

Figure C



## Lift Installation

### Turnbuckle Installation and Adjustment



Hinged platform halves are secured with and rotated on turnbuckles. Platform turnbuckles are fully adjusted during assembly procedures (control platform alignment and leveling). Turnbuckles are disconnected from the platform brackets for shipping purposes. Vibration during shipment can potentially affect turnbuckle adjustment.

1. Using the hand pump, carefully deploy platform to floor level. Be sure the platform stop blocks are in contact with the vertical arms (Photo A).

Warning: Keep clear of platform area during hand pump deployment. Hinged platform halves are not secured and could free fall.

2. Manually unfold both platform halves. Keep Hands Clear! The left platform tab must engage the right platform slot. See Photo D.

3. Both platform halves must be laying flat as shown in Figure 2. Install the left turnbuckle into the platform bracket with the turnbuckle stud facing outward (Photo B, right side shown). Adjust turnbuckle so stud enters the platform bracket and no tension is on the turnbuckle (adjust if needed only). No further adjustment of the left turnbuckle is necessary.

4. Install right turnbuckle into the platform bracket with the turnbuckle stud facing outward (Photo B).

5. Adjust right platform turnbuckle so that the inboard end of the right platform is slightly above the platform heel (Photo C).

6. Stow and deploy platform. Observe the platform tabs and platform slots to confirm proper alignment during platform deployment. If the left platform tabs are higher than the right platform slots, increase the length of the right turnbuckle (Figure 1). If the tabs are lower than the slots, decrease the length of the right turnbuckle.

Figure 1

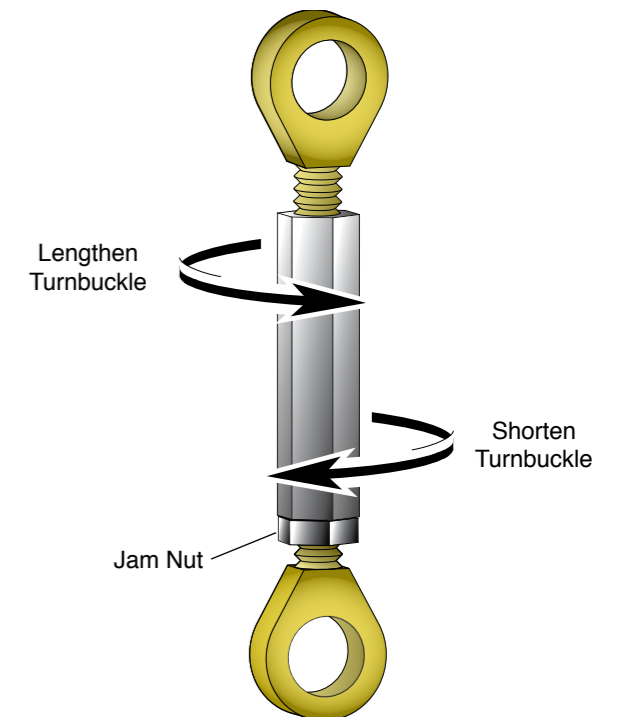

**Note:** Loosen jam nut to adjust turnbuckle length. Tighten jam nut after adjustment.

## Lift Installation

### Turnbuckle Installation and Adjustment

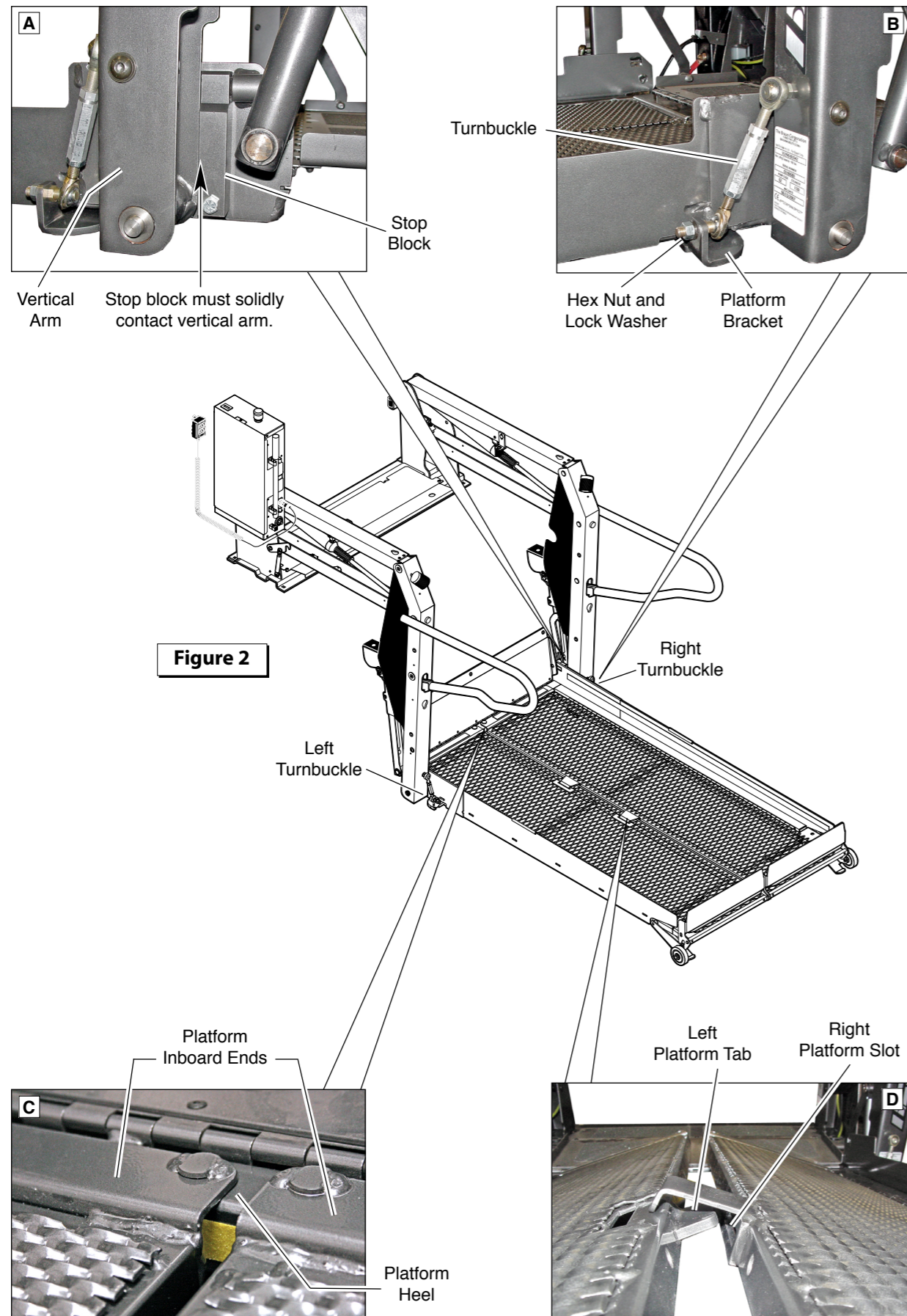

## Lift Installation

### Platform Half Stabilizer Roller Installation and Adjustment

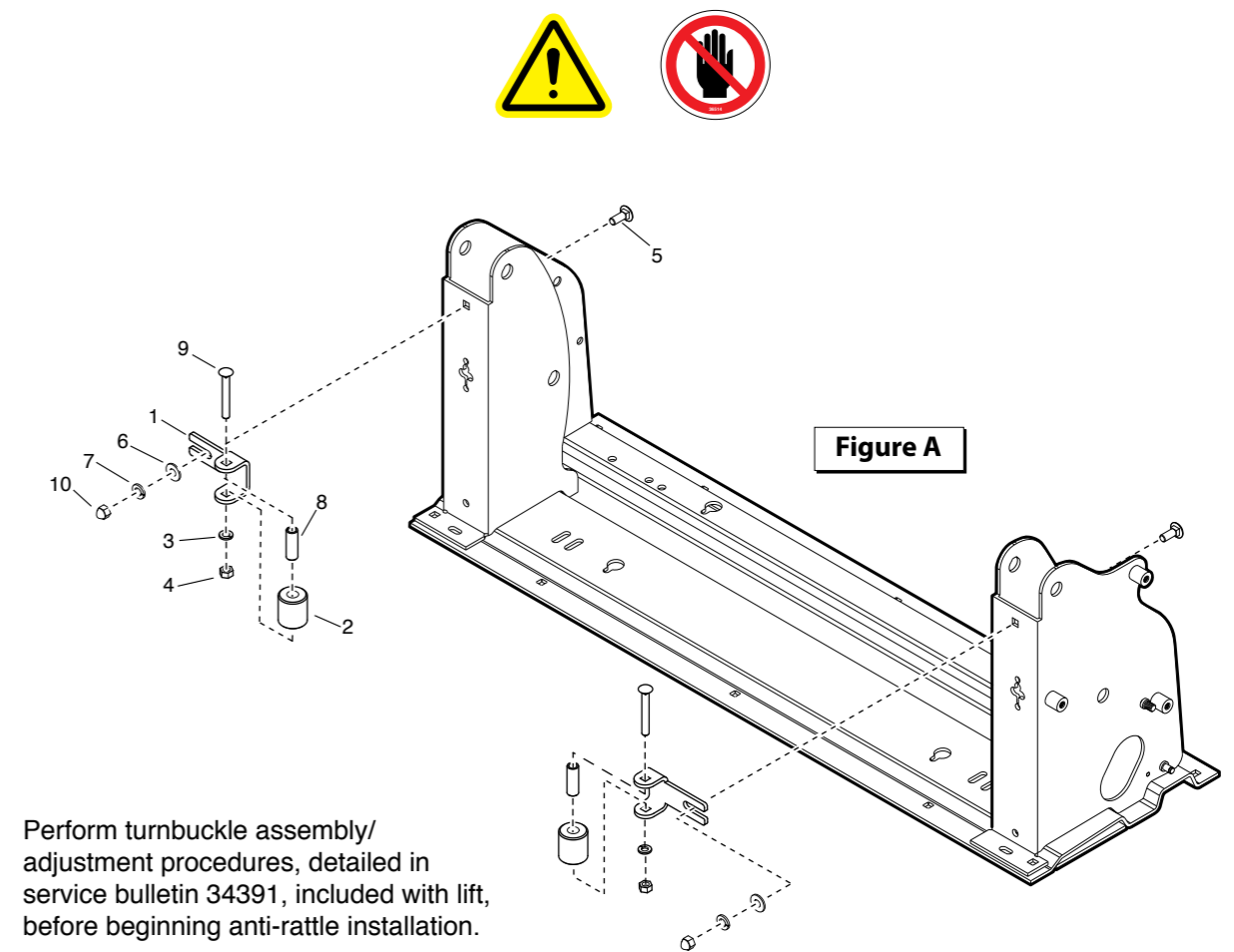

1. Unfold and lower platform to floor level.
2. Mount UHMW bumpers (Item 2) to mounting brackets (Item 1) as indicated using 5/16-18 X 2-1/4" carriage bolt (Item 9), roller axle (Item 8), lock washer (Item 3) and 5/16" hex nut (Item 4). Tighten securely.
3. Position and mount bracket and bumper assemblies to lift towers as shown. Secure to lift using 5/16-18 X 3/4" carriage bolt (Item 5), 1/4" flat washer (Item 6), 5/16" lock washer (Item 7), and 5/16" acorn nut (Item 10). Snug tighten.
4. Stow lift fully. Push bumpers tightly against platform halves (oval slots provide adjustment). Tighten securely. Test for rattle and adjust as needed.

## Lift Installation

### Roll Stop Anti-Rattle Installation and Adjustment

1. Mount bumper into slot in roll stop using 5/16-18 X 3/4" bolt and 3/8" star washer. Refer to figures B through D. Typical both sides.

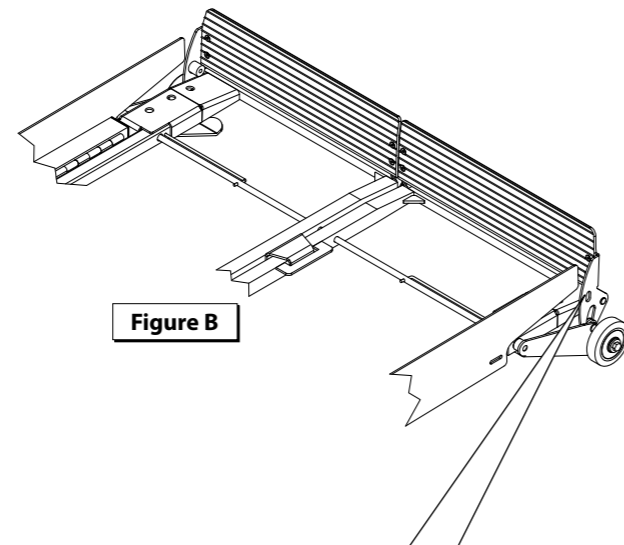

2. Pull outward on roll stop half and push bumper downward against platform surface (oval slot provides adjustment). Tighten securely. Test for rattle and adjust as needed. Typical both sides.

Note: Roll stop latch feet must drop completely to bottom of curved slots in roll stops to ensure proper latching.

Outer Barrier Slot

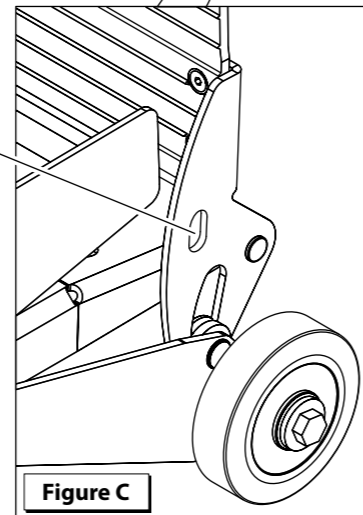

3. Verify proper latching operation of both roll stop halves.

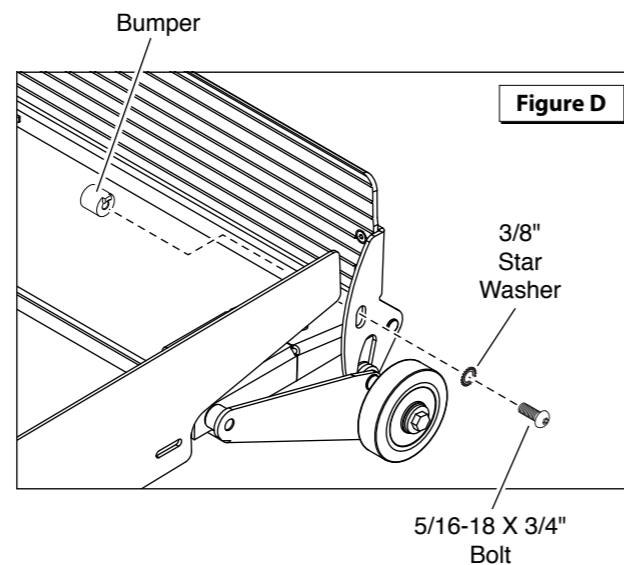

## Lift Installation

### Tower Microswitch Adjustment

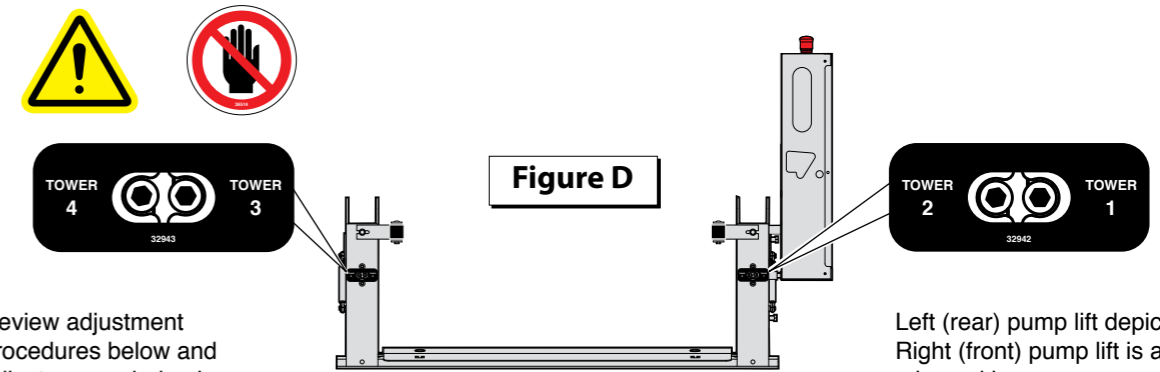

Review adjustment procedures below and adjust as needed only.

Left (rear) pump lift depicted. Right (front) pump lift is a mirrored image.

#### Tower 1 (Unfold) Switch Adjustment

Floor Position from Stow

1. Position platform at the fully stowed position using the manual hand pump or pendant control.
2. Turn switch adjustment screw clockwise 3 full turns.
3. Press pendant UNFOLD switch (continue pressing switch until platform stops unfolding).
4. When platform stops unfolding, turn switch adjustment screw counterclockwise while pressing the pendant UNFOLD switch. Platform position will change. Repeat adjustment until criteria below is met.

Proper Adjustment Criteria:

- Bridge plate should just rest on base plate cover. See Photo C.
- Should be an approximate 3 mm clearance between outboard end of rotating pivot slide arm saddle and the lower parallel arm. See Photo B.

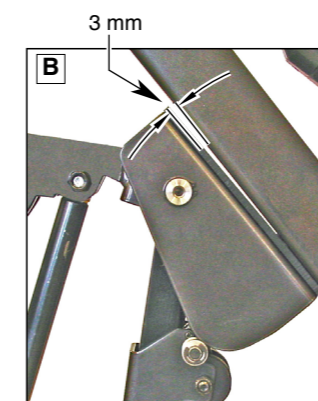

#### Tower 2 (Up) Switch Adjustment

Floor Position from Below Floor

1. Lower platform a minimum of 15.25 cm below floor level position using the manual hand pump or pendant control.
2. Turn switch adjustment screw counterclockwise 3 full turns.
3. Press pendant UP switch (continue pressing switch until platform stops).
4. When platform stops, turn switch adjustment screw clockwise while pressing the pendant UP switch. Platform position will change. Adjust platform to meet criteria listed for Tower 1 Switch "Proper Adjustment Criteria".

Bridge plate should rest on base plate cover.

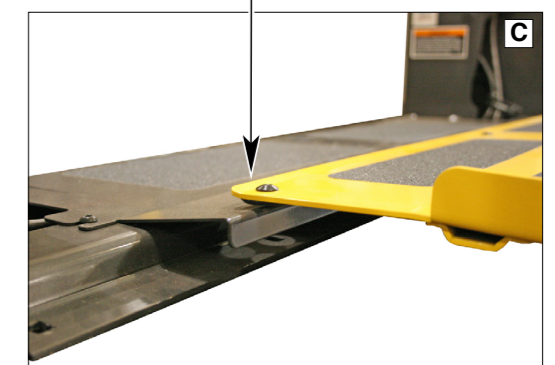

## Lift Installation

### Tower Microswitch Adjustment

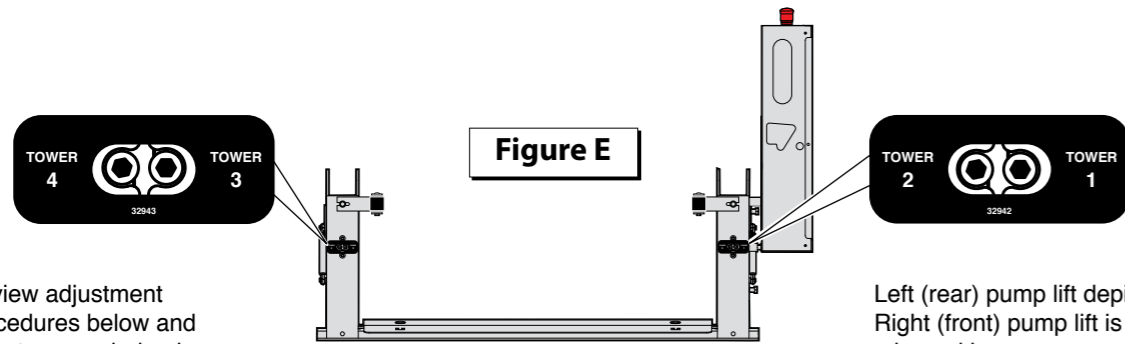

Review adjustment procedures below and adjust as needed only.

Left (rear) pump lift depicted. Right (front) pump lift is a mirrored image.

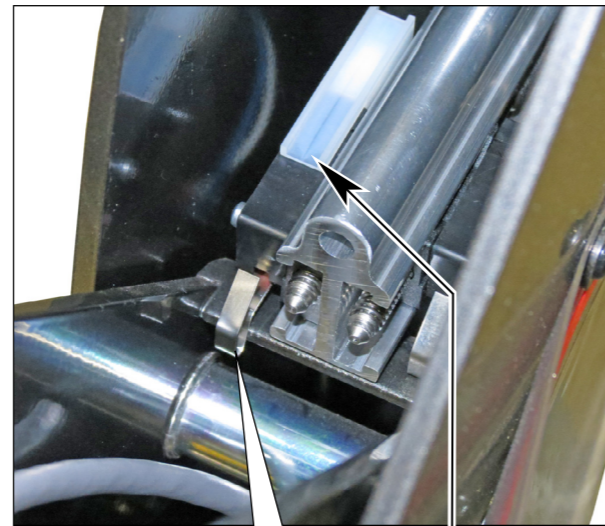

Tower 3 Microswitch

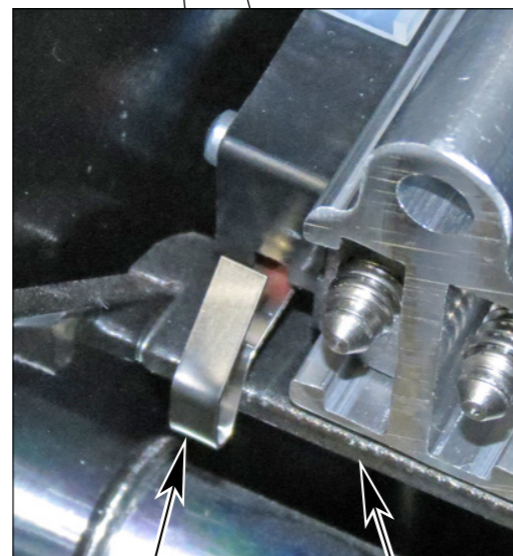

Microswitch Lever

Activation Plate

#### Tower 3 (Count) Switch Adjustment

Cycle Counter Switch

1. Position platform approximately 25 mm below floor level position using the pendant control.
2. View the Tower 3 microswitch inside the lift tower (see Photo H). Turn switch adjustment screw counterclockwise until microswitch no longer contacts the activation plate.
3. Observe the cycle count number on the LCD display. Slowly turn switch adjustment screw clockwise until the microswitch activates (clicks) and the number on the cycle counter LCD has changed.

#### Tower 4 Switch Adjustment

Not Used

Platform Angle Adjustment: Check platform angle after Tower Microswitch Adjustment procedures.

Platform Stop Blocks: Ensure both stop blocks are making full contact with the vertical arms.

## Installer Verification

### Compatibility between the lift and the vehicle

The installer shall confirm the compatibility between the lift and the vehicle.

### Static Test

#### Deformation

The unladen platform is positioned mid-way between ground level and vehicle floor level and measurements are taken of the height of the platform and its angular attitude relative to the vehicle floor.

A load of 454 kg is applied to the platform and subsequently removed.

By repeating measurements of the height and attitude of the platform, verify that no permanent deformation has occurred in any part of the lift or its attachment to the vehicle which could affect the function of the lift.

#### Drift

A load of 454 kg is applied to the platform, positioned at floor level. Measurements are taken of the height of the platform and its angular attitude relative to the vehicle floor. These measurements are repeated after a 15 minute test period.

Verify that the vertical drift of the platform between the two measurements has not exceeded 15mm.

Verify that the angular drift of the platform between the two measurements has not exceeded 2°.

#### Test to Verify that the Lift Cannot Lift Excessive Load

A load of 454 kg is applied to the platform, positioned at ground level. Actuate the UP control and verify that the platform does not lift (tilt is permissible).

1. Lower platform to the ground.
2. Place 454 kg at center of platform.
3. Press UP switch and verify platform does not lift (tilt is permissible).
4. If platform does not lift, proceed to Dynamic Test. If platform does lift, proceed to step 5, pump relief valve adjustment is necessary.
5. Access relief valve (see photos on following page). Loosen 9/16" hex nut on the relief valve adjustment screw (do not remove hex nut).
6. Turn adjustment screw counterclockwise 1/8 turn.
7. Press UP switch and verify platform does not lift (tilt is permissible).
8. If platform does not lift, tighten 9/16" hex nut (do not turn relief valve adjustment screw while tightening hex nut). If platform does lift, repeat steps 6 through 8

## Installer Verification

### Dynamic Test

With 363 kg applied to the platform, verify that the lift is able to operate throughout its full range of normal lifting and lowering.

1. Lower platform to the ground.
2. Place 363 kg at center of platform.
3. Press UP switch and verify that the lift is able to operate throughout its full range of normal lifting and lowering movements.
4. If platform is able to operate throughout its full range of normal lifting and lowering movements, no adjustment is necessary. If platform does not lift, proceed to step 5, pump relief valve adjustment is necessary.
5. Access relief valve (see illustration below). Loosen 9/16" hex nut on the relief valve adjustment screw (do not remove hex nut).
6. Turn adjustment screw clockwise 1/8 turn.
7. Press UP switch and verify lift is able to operate throughout its full range of normal lifting and lowering movement.
8. If lift does not operate throughout its full range, repeat steps 6 through 8. If lift does operate throughout its full range, tighten 9/16" hex nut (do not turn relief valve adjustment screw while tightening hex nut).

### Test of Operations and Safety Functions

All functions of the lift and operations of all safety devices are verified after the static and dynamic tests have been completed. These tests do not apply to pipe break valves nor non-resettable safety devices such as electrical fuses (These items are the subject of a manufacturer's type test).

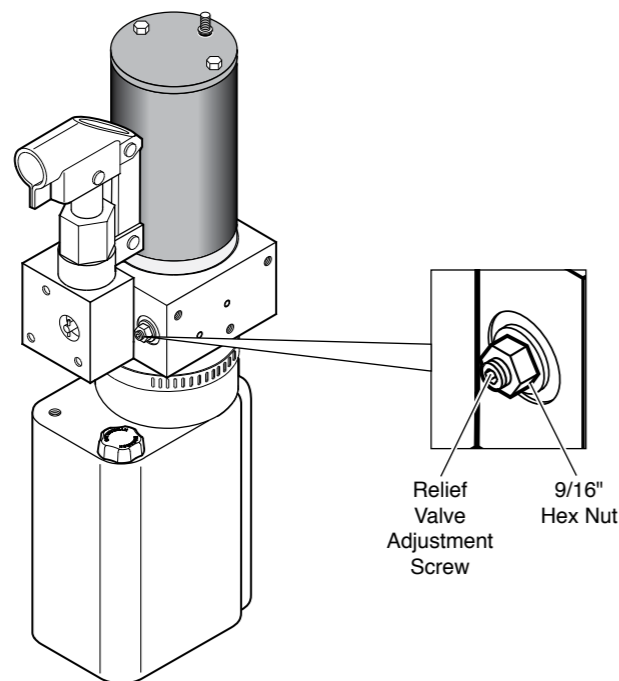

## Lift Operation Safety

### Safety Symbols

**SAFETY FIRST!** Know That....

**A** The information contained in this manual and supplements (if included), is provided for your use and safety. Familiarity with proper installation, operation, maintenance and service procedures is necessary to ensure safe, trouble free lift operation. Safety precautions are provided to identify potentially hazardous situations and provide instruction on how to avoid them.

**B**

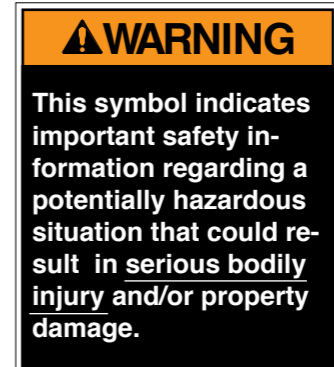

**C**

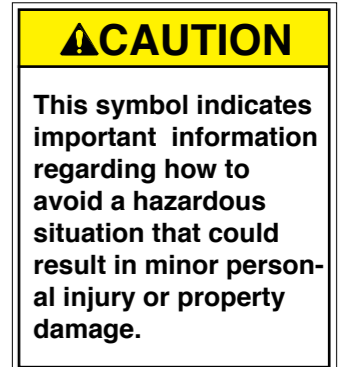

**D**

**NOTICE**

Additional information provided to help clarify or detail a specific subject.

**E**

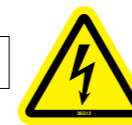

This symbol indicates that there are dangerous energy levels present inside the enclosure of this product. To reduce the risk of fire or electric shock, do not attempt to open the enclosure or gain access to areas where you are not instructed to do so. Refer servicing to qualified service personnel only.

**F**



This symbol indicates that a condition where damage to the equipment resulting in injury to the operator could occur if operational procedures are not followed. To reduce the risk of damage or injury, refer to accompanying documents, follow all steps or procedures as instructed.

**G**



This symbol indicates that a condition where injury or damage could occur if contact is made with the hot surface.

**H**



This symbol indicates an area to avoid bodily contact to prevent injury.

**I**



This symbol indicates the presence of high pressure hydraulic hoses. Use appropriate personal protective equipment when working on hydraulic system.

**J**



This symbol indicates the presence of a fire hazard. Avoid open flames or sparks when working with flammable materials to prevent injury or damage.

**K**



This symbol indicates a device weighs in excess of 139kg (306 lbs). Use of a fork lift or hoist is required.

These symbols will appear throughout this manual as well as on the labels posted on your lift. **Recognize the seriousness of this information.**

## Lift Operation Safety

### Lift Operation Safety Precautions

#### **⚠WARNING**

If the lift operating instructions, manual operating instructions and/or lift operation safety precautions are not fully understood, contact BraunAbility immediately. Failure to do so may result in serious bodily injury and/or property damage.

- ⚠WARNING** Read manual and supplement(s) before operating lift. Read and become familiar with all safety precautions, operation notes and details, operating instructions and manual operating instructions before operating the lift.
- ⚠WARNING** Load and unload on level surface only.
- ⚠WARNING** Engage vehicle parking brake before operating lift.
- ⚠WARNING** Provide adequate clearance outside the vehicle to accommodate the lift before opening lift door(s) or operating lift.
- ⚠WARNING** Inspect lift before operation. Do not operate lift if you suspect lift damage, wear or any abnormal condition.
- ⚠WARNING** Do not use as a link bridge.
- ⚠WARNING** Keep operator and bystanders clear of area in which the lift operates.
- ⚠WARNING** Lift attendant must observe passenger at all times during lift operation.
- ⚠WARNING** Ensure adequate lighting exists in the lift operating area.
- ⚠WARNING** Whenever a wheelchair passenger (or standee) is on the platform, the:
  - Passenger must be positioned fully inside yellow boundaries facing outward.
  - Wheelchair brakes must be locked
  - Bridge plate and roll stop must be up (vertical)
  - Roll Stop latch must be fully engaged
  - Passenger should grip both handrails (if able).
- ⚠WARNING** Wheelchair lift attendants should be instructed on any special needs and/or procedures required for safe transport of wheelchair passengers.
- ⚠WARNING** Load and unload clear of vehicular traffic.
- ⚠WARNING** Do not attempt to load or unload a passenger in a wheelchair or other apparatus that does not fit on the platform area.
- ⚠WARNING** The lift attendant shall not ride on the platform with the passenger. The lift is intended for use by a single passenger.
- ⚠WARNING** Do not overload or abuse. The load rating applies to both the raising and lowering functions.
- ⚠WARNING** Use caution when operating this equipment out of doors during electrical storms or similar electrical phenomena.
- ⚠WARNING** Use caution when operating this equipment in severe weather or environmental conditions (fog, rain, snow, ice, dust, etc.)
- ⚠WARNING** Discontinue lift use immediately if any lift or vehicle interlock does not operate properly.
- ⚠WARNING** Do not operate or board the lift if you or your lift operator are intoxicated.

## Lift Operation Safety

- ⚠WARNING** Do not raise front wheelchair wheels (pull wheelie) when loading, boarding, or riding on the platform.
- ⚠WARNING** Open lift door(s) fully and secure before operating lift.
- ⚠WARNING** Position and secure (buckle, engage, fasten, etc.) the wheelchair-equipped occupant seat belt (torso restraint) before loading onto the wheelchair lift platform.
- ⚠WARNING** Lift attendants must ensure that lift occupants keep hands, arms and all other body parts within the lift occupant area and clear of moving parts.
- ⚠WARNING** Platform must be positioned at floor level (bridging position) when loading or unloading in and out of vehicle.
- ⚠WARNING** Do not use platform bridge plate or roll stop as a brake. Stop and brake wheelchair when loading onto the platform (manually stop and brake manual wheelchairs — stop powered wheelchairs with the wheelchair controls).
- ⚠WARNING** Turn powered (electric) wheelchairs off when on lift platform.
- ⚠WARNING** Press the DOWN switch until the entire platform rests on ground level (lowered fully) and the roll stop is fully unfolded (ramp position) before loading or unloading a passenger at ground level.
- ⚠WARNING** Roll stop must be fully unfolded (ramp position) until front and rear wheelchair wheels cross the barrier when loading or unloading at ground level.
- ⚠WARNING** Accidental activation of control switch(es) may cause unintended operation(s).
- ⚠WARNING** Maintenance and lubrication procedures must be performed as specified in this manual by authorized (certified) service personnel.
- ⚠WARNING** Replace missing, worn or illegible decals.
- ⚠WARNING** Never modify (alter) a BraunAbility lift.
- ⚠WARNING** Do not use accessory devices not authorized by BraunAbility.
- ⚠WARNING** Do not remove any guards or covers.
- ⚠WARNING** Keep clear of any hydraulic leak.
- ⚠WARNING** Failure to follow these safety precautions may result in serious bodily injury and/or property damage.



## Lift Operating Instructions



Before lift operation, park the vehicle on a level surface, away from traffic. Place the vehicle transmission in "Park" and engage the parking brake. Vehicle engine must be running.

Lift Operating Instructions address operation of the lift only.

Vehicle Doors and Vehicle Interlocks: Transit vehicle lift doors and interlocks vary. Procedures to operate them vary also. Lift operators

(attendants) must become familiar with the vehicle lift access door system and vehicle interlock(s).

Manual Door(s): Open manual doors fully and secure in full open position before operating the lift.

Do not operate the lift if you suspect lift damage, wear, or any abnormal condition. Refer to the Manual Operating Instructions to manually operate lift.

**Lift Power ON/OFF Switch:** This switch must be in the ON position in order to activate the lift. The green Power Indicator Light illuminates to signal power to the lift.

**Hand-held Pendant Control:** The hand-held attendant's pendant control is equipped with two rocker switches. When there is power to the lift, the lift function labels illuminate to identify the functions.

### Control Switch Functions:

**UP:** From ground level, the UP function will raise (rotate) the roll stop to the vertical position. The platform then raises to floor level position.

**DOWN:** From floor level, the DOWN function lowers the platform to ground level and then unfolds (lowers) the roll stop to the ramp (horizontal) position.

**FOLD:** From floor level, the FOLD function folds the platform inward to the stowed position.

**UNFOLD:** From stowed position, the UNFOLD function unfolds the platform outward to the floor position.

Note: If any functions do not occur as described, discontinue lift use immediately.

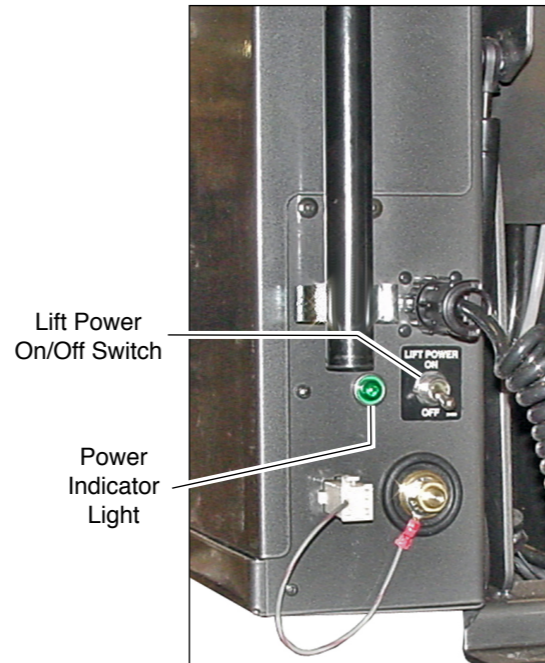

Hand-held Pendant Control



## Lift Operating Instructions

Before lift operation, park on a level surface, away from vehicular traffic. Place the vehicle

transmission in "Park" and engage the parking brake. Vehicle engine must be running. Refer

to the Manual Operating Instructions to manually operate lift.

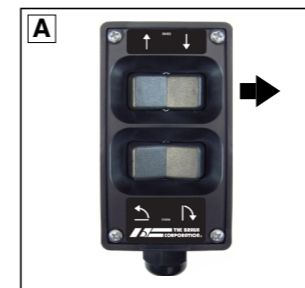

### OPEN DOOR(S) AND SECURE

#### TO UNFOLD PLATFORM:

Stand clear and press the UNFOLD switch until the platform stops (reaches floor level - unfolds fully). Release switch.

Notice: In event platform does not unfold, press FOLD switch to release Lift-Tite™ latches.

#### TO UNLOAD PASSENGER:

1. Read Notice below! Load passenger onto platform and lock wheelchair brakes.

Notice: Passenger must be positioned fully inside yellow boundaries, roll stop must be UP, and roll stop latch must be engaged.

2. Press DOWN switch until the entire platform reaches ground level (see Photo B) and the roll stop unfolds fully (ramp position). See Photo C. Release switch.

3. Unlock wheelchair brakes and unload passenger from platform.

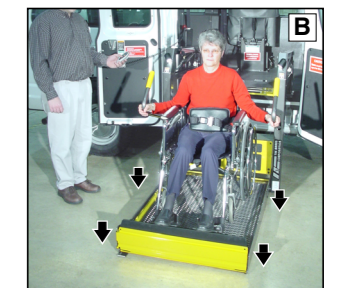
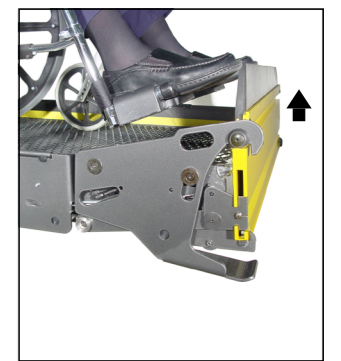

## Lift Operating Instructions

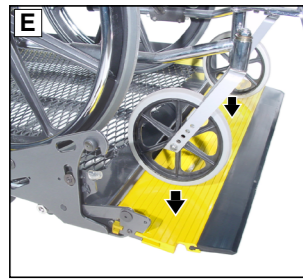

Notice: Roll stop must be fully unfolded (ramp position) until the entire wheelchair (or standee) has crossed the roll stop. See Photos E and F.

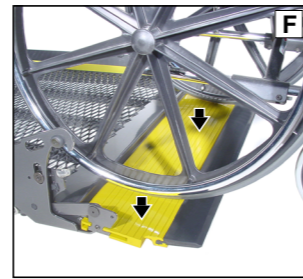

### TO LOAD PASSENGER:



1. Read Notices below! Load passenger onto platform and lock wheelchair brakes. See Photo G.

Notice: Roll stop must be fully unfolded (ramp position) until the entire wheelchair (or standee) has crossed the roll stop. See Photos E and F.

Notice: Passenger must be positioned fully inside yellow boundaries.

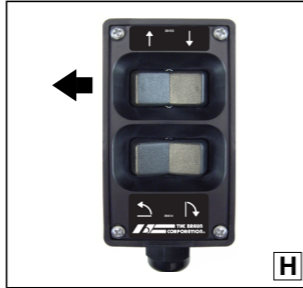

2. Press ↑ UP switch (Photo H) to fold roll stop UP fully (vertical - see Photo I), and raise the platform to floor level. See Photo J. Release switch.

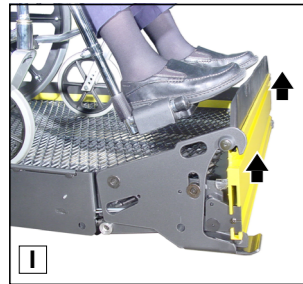

3. Unlock wheelchair brakes and unload passenger from platform.

### TO FOLD PLATFORM:

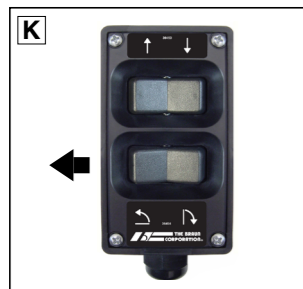

Press ↶ FOLD (In) switch until platform stops (fully folded). See Photos K and L. Release switch



### CLOSE DOOR(S)

## Manual Operating Instructions

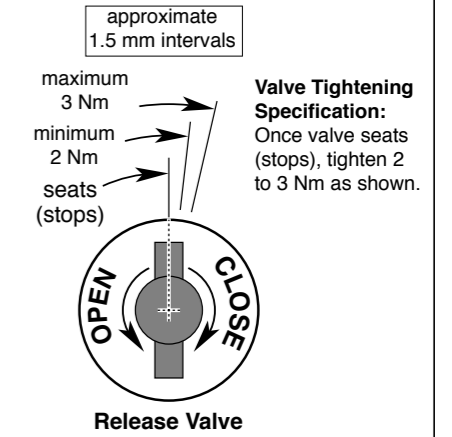
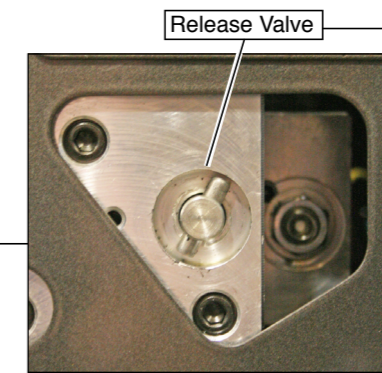
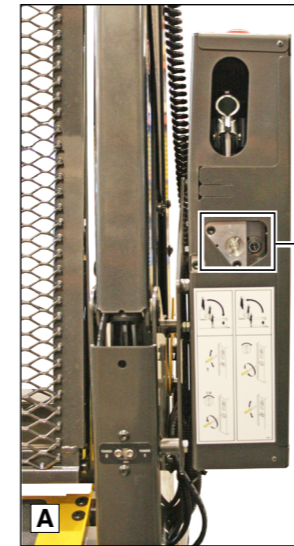

Notice: Close backup pump release valve securely before operating electric pump.

Hand Pump Handle

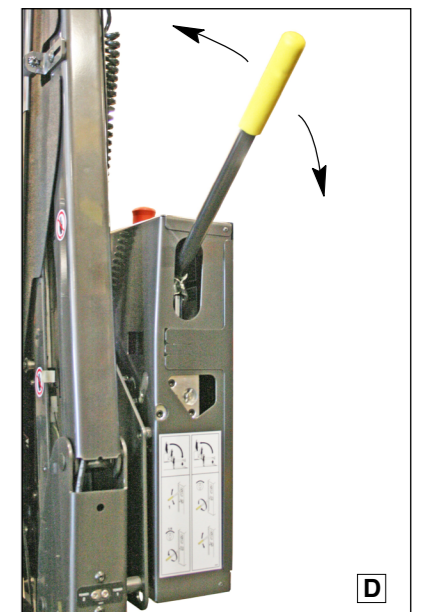
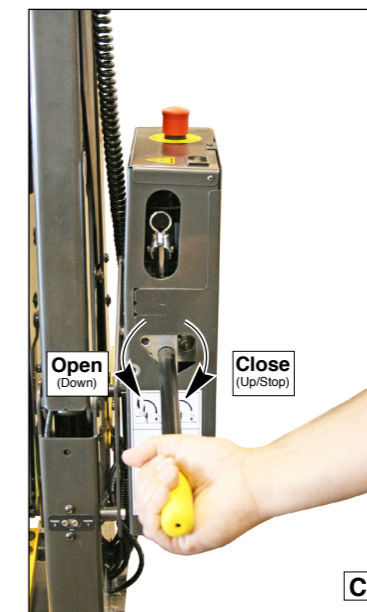
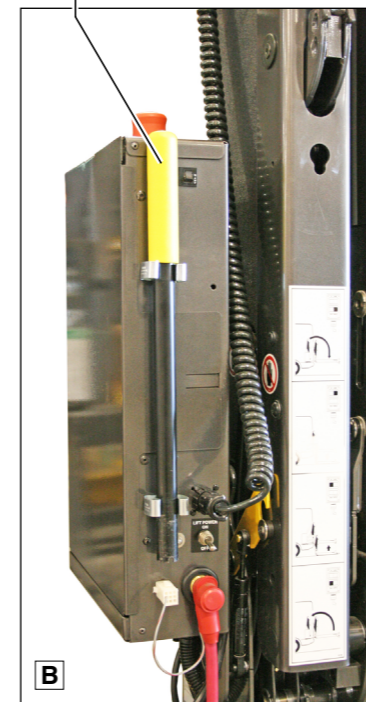

Notice: Bridge plate and roll stop automatically function during manual operations.

## Manual Operating Instructions

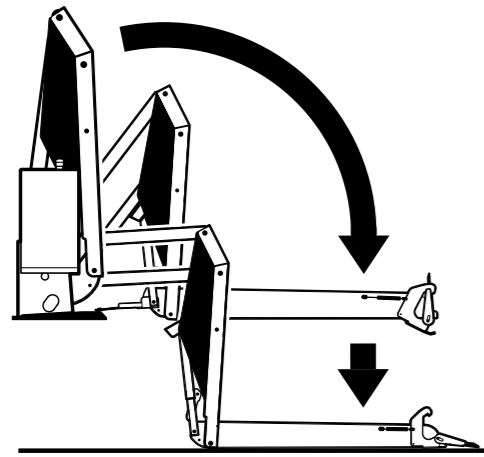

### To Unfold Platform (Out):

Using hand pump handle (Photo B):

1. Close hand pump valve (place slotted end of pump handle onto release valve and turn clockwise). See Photo C.
2. Insert handle in pump and stroke until platform folds fully (stops). See Photo D.
3. Open hand pump valve (turn counterclockwise) until platform reaches floor level. Open 1/4 turn only.
4. Close hand pump valve (turn clockwise).

Notice: Valve must be tight, but do not overtighten.

### Down (To Lower):

Place slotted end of pump handle onto release valve and turn counterclockwise (open 1/4 turn only) until the platform reaches ground level and the roll stop unfolds. See Photo C.

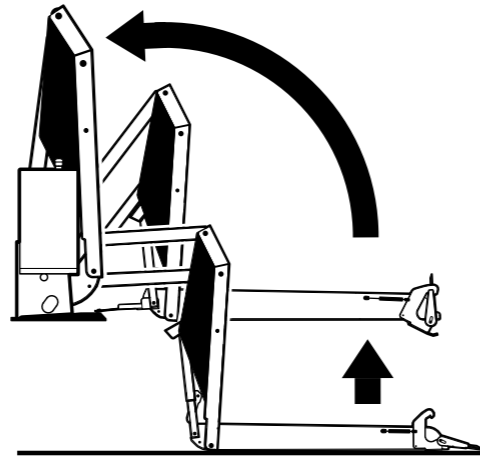

### Up (To Raise):

Using hand pump handle:

- a. Place slotted end of pump handle onto release valve and turn clockwise to close securely. See Photo C.
- Notice: Valve must be tight, but do not overtighten.
- b. Insert handle into back-up pump and stroke until platform reaches floor level (see Photo D).

### To Fold Platform (In):

Insert handle in pump and stroke until platform stops (folds fully). See Photo D.

Notice: Close release valve securely before operating electric pump. Store pump handle in clamps shown in Photo B.

## Emergency Stop (E-Stop) Operating Instructions

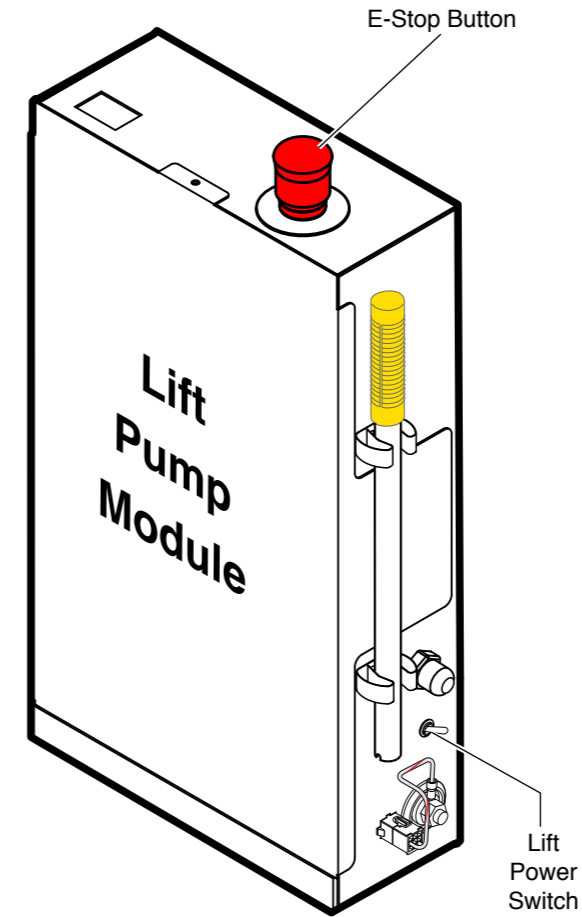

To Activate E-Stop:  
Push E-Stop button down.

To Reset E-Stop:

1. Turn lift power OFF.
2. Pull E-Stop button up.
3. Turn lift power ON.

## Maintenance and Lubrication



Proper maintenance is necessary to ensure safe, trouble-free lift operation. Inspecting the lift for any wear, damage or other abnormal conditions should be a part of the transit agency daily service program. Simple inspections can detect potential problems.

Park vehicle on a level surface clear of traffic and bystanders. Place vehicle transmission in "Park" and engage parking brake. Deploy lift to ground level. Provide adequate work space around fully-deployed lift. Perform specified maintenance and lubrication procedures (position lift as required).

**Pump Module:** When cleaning the exterior of the pump module, first disconnect the unit from its power source. Do not use liquid cleaners, aerosols, abrasive pads, scouring powders or solvents, such as benzine or alcohol. Use a soft cloth lightly moistened with a mild detergent solution. Ensure the surface cleaned is fully dry before reconnecting power.

**Other Components:** Clean components and the surrounding area before applying lubricants. Clean only with mild detergent and water. Do not clean with solvents. Allow the lift to dry thoroughly and apply lubricants as specified after every cleaning.

LPS2 General Purpose Penetrating Oil is recommended where Light Oil is called out. Use of improper lubricants can attract dirt or other contaminants which could result in wear or damage to

components. Platform components exposed to contaminants when lowered to the ground may require extra attention.

Perform maintenance and lubrication procedures at the scheduled intervals according to the number of cycles.

When servicing the lift at the recommended intervals, inspection and lubrication procedures specified in the previous sections should be repeated.

These intervals are a general guideline for scheduling maintenance procedures and will vary according to lift use and conditions. Lifts exposed to severe conditions (weather, environment, contamination, heavy usage, etc.) may require inspection and maintenance procedures to be performed more often than specified.

Records of maintenance and service procedures should be maintained.

Discontinue lift use if maintenance and lubrication procedures are not properly performed, or if there is any sign of wear, damage or improper operation. Contact your sales representative.

**WARNING**

**Maintenance and lubrication procedures must be performed as specified by an authorized service technician. Failure to do so may result in serious bodily injury and/or property damage.**

## Maintenance and Lubrication Schedule

### Lubrication Diagram

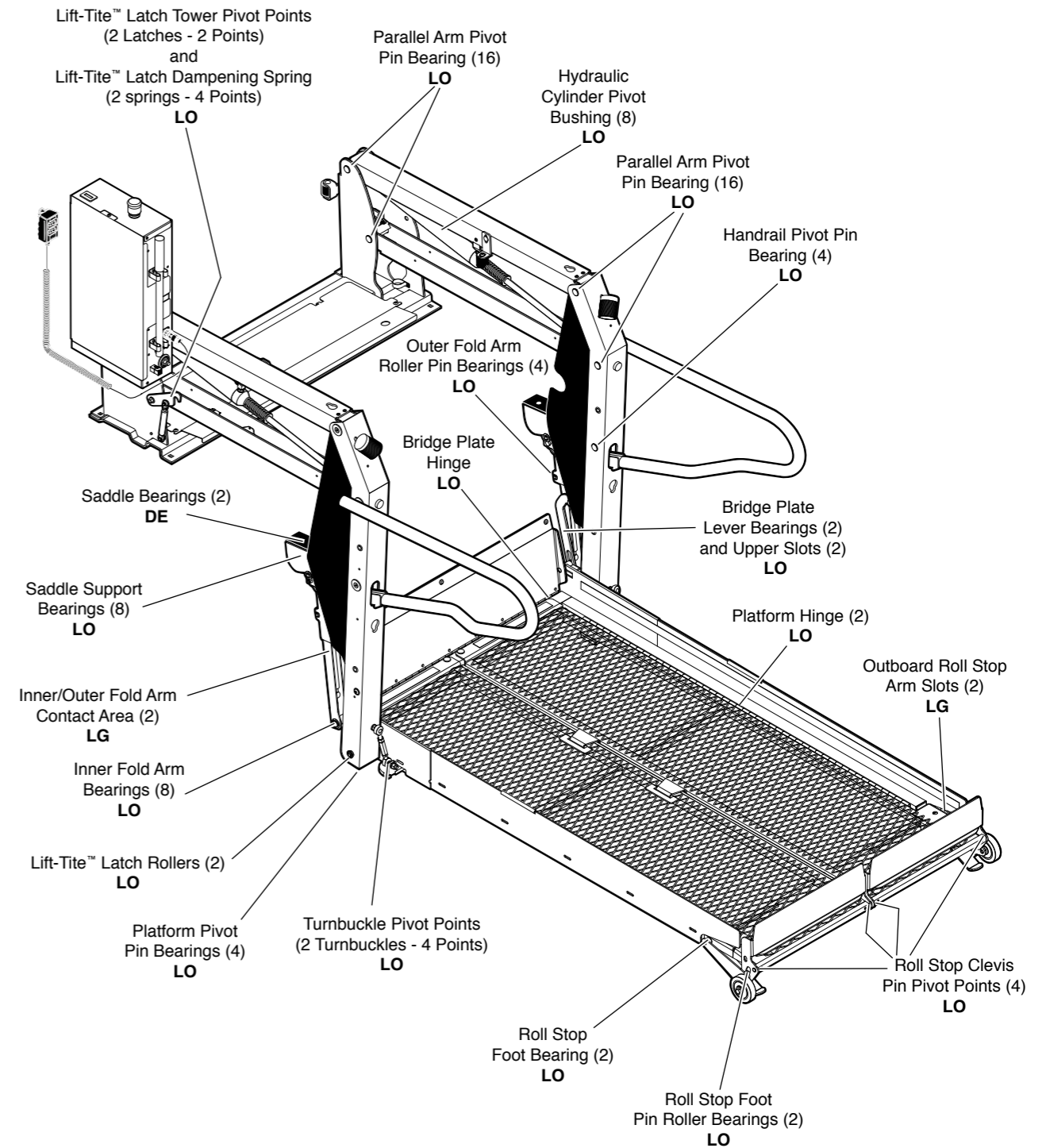

See the Maintenance/Lubrication Schedule for recommended applications per number of cycles.

Lubricant	Type	Specified (recommended) Lubricant	Available Amount	BraunAbility Part No.
<b>LO - Light Oil</b>	Light Penetrating Oil (30 weight or equivalent)	LPS2, General Purpose Penetrating Oil	16 oz. Aerosol Can	15807
<b>DE - Door-Ease</b>	Stainless Stick Style (tube)	Door-Ease Stick (tube)	1.68 oz.	15806
<b>LG - Light Grease</b>	Light Grease (Multipurpose)	Lubriplate	14 oz. Can	15805

## Maintenance and Lubrication Schedule

<b>750 Cycles</b>	Bridge plate hinge	Apply Light Oil - See Lubrication Diagram
	Platform hinges (2)	Apply Light Oil - See Lubrication Diagram
	Roll stop clevis pin pivot points (4)	Apply Light Oil - See Lubrication Diagram
	Roll stop pin roller bearings (2)	Apply Light Oil - See Lubrication Diagram
	Roll stop foot bearings (2)	Apply Light Oil - See Lubrication Diagram
	Roll stop arm slots (2)	Apply Light Grease - See Lubrication Diagram
	Lift-Tite™ latches tower pivot points (2 latches - 2 points)	Apply Light Oil - See Lubrication Diagram
	Lift-Tite™ latch gas (dampening) spring pivot points (2 springs - 4 points)	Apply Light Oil - See Lubrication Diagram
	Inspect Lift-Tite™ latches and gas springs for wear or damage (bent, deformed or misaligned), positive securement (external snap rings) and proper operation	Resecure, replace damaged parts or otherwise correct as needed. Notice: Apply Light Grease to Lift-Tite™ latch tower pivot point if replacing latch.
	Inspect bridge plate and roll stop for proper operation	Correct or replace damaged parts.
	Inspect roll stop foot pivot for proper operation, positive securement, and detached or missing spring	Correct or replace damaged parts and/or relubricate. See Lubrication Diagram
	Platform turnbuckle pivot points (2 turnbuckles - 4 points)	Apply Light Oil - See Lubrication Diagram
Inspect lift for wear, damage or any abnormal condition	Correct as needed.	
Inspect lift for rattles	Correct as needed	
Adjust fold pressure and roll stop fold pressure (if applicable).	See service manual.	

## Maintenance and Lubrication Schedule

<b>1500 Cycles</b>	Inner/Outer fold arms (2)	Apply grease (synthetic) to contact areas between upper/lower fold arms. See Lubrication Diagram.
	Platform pivot pin bearings (4)	Apply Light Oil - See Lubrication Diagram
	Inner fold arm bearings (8)	Apply Light Oil - See Lubrication Diagram
	Bridge plate lever bearings (2)	Apply Light Oil - See Lubrication Diagram
	Bridge plate lever upper slots (2)	Apply Light Oil - See Lubrication Diagram
	Saddle support bearings (8)	Apply Light Oil - See Lubrication Diagram
	Outer fold arm roller pin bearings (4)	Apply Light Oil - See Lubrication Diagram
	Parallel arm pivot bearings (16)	Apply Light Oil - See Lubrication Diagram
	Handrail pivot pin bearings (4)	Apply Light Oil - See Lubrication Diagram
	Hydraulic cylinder bushings (8)	Apply Light Oil - See Lubrication Diagram
	Inspect bridge plate for: • Wear or damage • Proper operation. Bridge plate should just rest on top surface of the base plate. • Positive securement (both ends)	Resecure, replace or correct as needed. See Platform Angle Instructions and Microswitch Adjustment Instructions.
	Inspect handrail components for wear or damage, and for proper operation	Replace damaged parts.
	Inspect microswitches for securement and proper adjustment.	Resecure, replace or adjust as needed. See Microswitch Adjustment Instructions.
	Make sure lift operates smoothly	Realign towers and vertical arms. Lubricate or correct as needed.
	Inspect roll stop clevis pin securement set screws	Resecure or replace (apply Loctite® Threadlocker Red 271™ or equivalent).

## Maintenance and Lubrication Schedule

<b>1500 Cycles</b>	<p>Inspect external snap rings:  <ul style="list-style-type: none"> <li>• Platform slide/rotate pivot pins (2 per pin)</li> <li>• Platform fold axles (1 per axle)</li> <li>• Bridge plate lever bracket pins (1 per pin)</li> <li>• Lift-Tite™ latch gas (dampening) spring (2 per spring)</li> <li>• Roll stop clevis pins (1 per pin)</li> <li>• Roll stop foot pins (2)</li> <li>• Platform pivot pins (2)</li> </ul> </p>	Resecure or replace if needed.
	<p>Inspect inner fold arm pins (2), axles (2) and bearings (8) for wear or damage and positive securement</p>	Replace damaged parts and resecure as needed. Apply Light Oil.
	<p>Inspect turnbuckle assemblies for wear or damage, proper operation and positive securement</p>	Resecure, replace or correct as needed. Apply light oil.
	<p>Remove pump module cover and inspect:  <ul style="list-style-type: none"> <li>• Hydraulic hoses, fittings and connections for wear or leaks</li> <li>• Harness cables, wires, terminals and connections for securement or damage</li> <li>• Relays, fuses, circuit breaker, and power switch for securement or damage</li> </ul> </p>	Resecure, replace or correct as needed.
	<p>Inspect Lift-Tite™ latch rollers for wear or damage, positive securement and proper operation (2)</p>	Correct, replace damaged parts and/or relubricate.

<b>4500 Cycles</b>	<p>Inspect cotter pins on platform pivot pins (2)</p>	Resecure, replace or correct as needed
	<p>Hydraulic Fluid (Pump) - Check level. Notice: Fluid should be changed if there is visible contamination. Inspect the hydraulic system (cylinder, hoses, fittings, seals, etc.) for leaks if fluid level is low.</p> <p>Inspect cylinders, fittings and hydraulic connections for wear, damage or leaks</p>	<p>Use BraunAbility 32840-QT hydraulic fluid (Exxon® Unavis HVI 26). Do not mix with Dextron III or other hydraulic fluids. Check fluid level with platform lowered fully. Fill to maximum fluid level indicated on reservoir (specified on decal). Do not overfill. If fluid level decal is not present - measure 35 mm from the fill port to locate fluid level.</p> <p>Tighten, repair or replace if needed.</p>

## Maintenance and Lubrication Schedule

<b>4500 Cycles</b>	<p>Inspect parallel arms, bearings and pivot pins for visible wear or damage</p>	Replace if needed.
	<p>Inspect parallel arm pivot pin mounting bolts (8)</p>	Tighten or replace if needed.
	<p>Inspect platform pivot pin, bearings and vertical arms for wear, damage and positive securement</p>	Replace damaged parts and resecure as needed. Apply Light Grease during reassembly procedures.
	<p>Inspect inner/outer fold arms, saddle, saddle support and associated pivot pins, bushings, and bearings for visible wear or damage</p>	Replace if needed.
	<p>Inspect gas springs (cylinders) for wear or damage, proper operation and positive securement</p>	Tighten, replace or correct as needed
	<p>Inspect saddle bearings (2)</p>	Apply Door-Ease or replace if needed. See Lubrication Diagram.
	<p>Inspect vertical arm plastic covers</p>	Resecure or replace if needed.
	<p>Inspect power cable Mounting</p>	Resecure, repair or replace if needed. Check to see that the lift is securely anchored to the vehicle and there are no loose bolts, broken welds, or stress fractures.
<p>Decals and Antiskid</p>	Replace decals if worn, missing or illegible. Replace antiskid if worn or missing.	

<b>Consecutive 750 Cycle Intervals</b>	Repeat all previously listed inspection, lubrication and maintenance procedures at 750 cycle intervals.
------------------------------------------------	---------------------------------------------------------------------------------------------------------

## Maintenance and Lubrication Schedule

<b>Lift Disposal Procedure</b>	<p>2000-53-EC Disassembly and Disposal Guidelines</p> <p>No lift components contain unacceptable amounts of lead, cadmium, mercury, or hexavalent chromium.</p> <ol style="list-style-type: none"> <li>1. Lower platform to ground.</li> <li>2. Open pump module manual relief valve.</li> <li>3. Disconnect power from lift.</li> <li>4. Capture and recycle hydraulic fluid.</li> <li>5. Disassemble lift and recycle components.</li> </ol> <p>Refer to exploded views in appropriate service manual.</p>



<b>EC Declaration of Conformity With Council Directive 2006/42/EC</b>		
Date of Issue:	1 April 2014	
Directive:	Machinery Directive on machinery safety, 2006/42/EC	
Conforming Machinery:	Dual Parallel Arm Hydraulic Lift System Century -2, Millennium -2, Vista -2, GL Series 04 and newer, GCL and GVL Series 05 and newer Lifts	
Manufacturer:	BraunAbility 631 West 11 <sup>th</sup> Street Winamac, IN 46996 USA	
Authorized Representative:	<p>BraunAbility Authorized Representative</p> <p>AUTOADAPT AB Åkerivägen 7 S-443 61 Stenkullen SWEDEN Telephone: +46 (0) 302 254 00 E-mail: contact@autoadapt.se</p> <p>AUTOADAPT UK LTD Unit 1, Windsor Industrial Estate, Rupert Street Aston, Birmingham B7 4PR, UK Phone: +44 (0) 121 33 35 170 E-mail: contact@autoadapt.co.uk</p>	
Harmonized Standards, Directives, and Regulations Referenced or Applied:	EN 13857:2008, EN ISO 13850:2008, EN ISO 14121-1:2007, EN 349:1993+A1:2008, EN 953:1997+A1:2009, EN 1037:1995+A1:2008, EN 982:1996+A1:2008, EN 614-1:2006+A1:2009, EN 60204-1:2006, EN 1756-2:2004+A1:2009 ECE R-107	
Specifications with which Conformity is Declared:	Essential Health and Safety Requirements of Annex 1 of the Machinery Directive	
We hereby certify that the machinery described above conforms with the essential health and safety requirements of Council Directive 2006/42/EC on the approximation of the laws of the Member States relating to the safety of machinery.		
Technical File Reference Number	SF10933A1.BC	

### Declaration of Noise Emission

Date of Issue:	1 April 2014	
Manufacturer:	BraunAbility 631 West 11 <sup>th</sup> Street Winamac, IN 46996 USA	
Authorized Representative:	BraunAbility Authorized Representative  AUTOADAPT AB Åkerivägen 7 S-443 61 Stenkullen SWEDEN Telephone: +46 (0) 302 254 00 E-mail: contact@autoadapt.se  AUTOADAPT UK LTD Unit 1, Windsor Industrial Estate, Rupert Street Aston, Birmingham B7 4PR, UK Phone: +44 (0) 121 33 35 170 E-mail: contact@autoadapt.co.uk	
		
BraunAbility Wheelchair Lift Systems Sound Pressure Levels per EN ISO 11202 as based on testing on similar models are as follows:		
	<b>Operating</b>	<b>Idle</b>
<b>L<sub>pAm</sub></b> (Operator Position)	75 dB (A)	68 dB (A)
<b>L<sub>pAm</sub></b> (Bystander Position)	73 dB (A)	69 dB (A)
Ambient Correction Factor K3A calculated according to EN ISO 11204 Appendix A.		4 dB (A)
Measurements were made at a height of 1.5 m and 1 m from the Operator Position and Bystander positions.		
The difference between the extraneous noise level and the sound intensity level at each measuring point is:		<b>L<sub>pAm</sub> Δ = 6 dB (A)</b>
The figures quoted are emission levels and are not necessarily safe working levels. While there is a correlation between the emission and exposure levels this cannot be used reliably to determine whether or not further precautions are required.		
Factors that influence the actual level of exposure of the workforce include characteristics of the work room, the other sources of noise, etc. such as the number of machines and other adjacent processes. Also, the permissible level of exposure can vary from country to country.		
This information, however, will enable the user of the machine to make a better evaluation of the hazard and risk.		
Technical File Reference Number	SF10933A1.BC	

### Declaration of Conformity With Directive 72/245/EEC - 2009/19/EC



Date of Issue:	1 April 2014
Directive:	Radio Interference of Vehicles 72/245/EEC - 2009/19/EC
Conforming Machinery:	Dual Parallel Arm Hydraulic Lift System Century -2, Millennium -2, Vista -2, VL998, GL Series 04 and newer, GCL and GVL Series 05 and newer Lifts
Manufacturer:	BraunAbility 631 West 11 <sup>th</sup> Street Winamac, IN 46996 USA
Authorized Representative:	BraunAbility Authorized Representative  AUTOADAPT AB Åkerivägen 7 S-443 61 Stenkullen SWEDEN Telephone: +46 (0) 302 254 00 E-mail: contact@autoadapt.se  AUTOADAPT UK LTD Unit 1, Windsor Industrial Estate, Rupert Street Aston, Birmingham B7 4PR, UK Phone: +44 (0) 121 33 35 170 E-mail: contact@autoadapt.co.uk
Harmonized Standards, Directives, and Regulations Referenced or Applied:	EN50498:2010 UN ECE R-10 Rev. 4:2012, including amendment 2013
We hereby certify that the machinery described above conforms with Directive 72/245/EEC - 2009/19/EC	
Technical File Reference Number	SF10933A1.BC



Owner Manual  
International  
**Vista 2**  
**63" Split**  
**Platform**

Public Use  
Wheelchair Lifts

BraunAbility® Limited Warranty

Consult your local BraunAbility® dealer regarding warranty policy.

[www.braunability.com/international](http://www.braunability.com/international)

Patent #5,261,779

Patent #6,464,447

Patent #6,739,824

Patent #6,065,924

Patent #6,599,079

Patent #7,306,422

Patent #6,238,169

Patent #6,692,217

Patent #7,422,408



[www.braunability.com/international](http://www.braunability.com/international) ISO 9001:2008

631 West 11th Street, Winamac, IN 46996, USA

Phone: +1 574 946 6153

Fax: +1 574 946 4670

38250 Rev. B

April

2014



All illustrations, descriptions and specifications in this manual are based on the latest product information available at the time of publication. The Braun Corporation reserves the right to make changes at any time without notice.

Original Instructions